



2836 Series Electric Fryers Service and Parts Manual

See manual 819-6049 for earlier float-switch equipped fryer



Frymaster Dean, a member of the Commercial Food Equipment Service Association, recommends using CFESA Certified Technicians.

24-Hour Service Hotline 1-800-551-8633

www.frymaster.com

Email: service@frymaster.com

SEPT 2011
8196114

NOTICE

IF, DURING THE WARRANTY PERIOD, THE CUSTOMER USES A PART FOR THIS MANITOWOC EQUIPMENT OTHER THAN AN UNMODIFIED NEW OR RECYCLED PART PURCHASED DIRECTLY FROM FRYMASTER DEAN, OR ANY OF ITS AUTHORIZED SERVICE CENTERS, AND/OR THE PART BEING USED IS MODIFIED FROM ITS ORIGINAL CONFIGURATION, THIS WARRANTY WILL BE VOID. FURTHER, FRYMASTER DEAN AND ITS AFFILIATES WILL NOT BE LIABLE FOR ANY CLAIMS, DAMAGES OR EXPENSES INCURRED BY THE CUSTOMER WHICH ARISE DIRECTLY OR INDIRECTLY, IN WHOLE OR IN PART, DUE TO THE INSTALLATION OF ANY MODIFIED PART AND/OR PART RECEIVED FROM AN UNAUTHORIZED SERVICE CENTER.

NOTICE

This appliance is intended for professional use only and is to be operated by qualified personnel only. A Frymaster Dean Factory Authorized Servicer (FAS) or other qualified professional should perform installation, maintenance, and repairs. Installation, maintenance, or repairs by unqualified personnel may void the manufacturer's warranty. See Chapter 1 of this manual for definitions of qualified personnel.

NOTICE

This equipment must be installed in accordance with the appropriate national and local codes of the country and/or region in which the appliance is installed.

NOTICE

Drawings and photos used in this manual are intended to illustrate operational, cleaning and technical procedures and may not conform to onsite management operational procedures.

NOTICE TO OWNERS OF UNITS EQUIPPED WITH COMPUTERS

U.S.

This device complies with Part 15 of the FCC rules. Operation is subject to the following two conditions: 1) This device may not cause harmful interference, and 2) This device must accept any interference received, including interference that may cause undesired operation. While this device is a verified Class A device, it has been shown to meet Class B limits.

CANADA

This digital apparatus does not exceed the Class A or B limits for radio noise emissions as set out by the ICES-003 standard of the Canadian Department of Communications.

Cet appareil numérique n'émet pas de bruits radioélectriques dépassant les limites de classe A et B prescrites dans la norme NMB-003 édictée par le Ministre des Communications du Canada.

 **DANGER**

Improper installation, adjustment, maintenance or service, and unauthorized alterations or modifications can cause property damage, injury, or death. Read the installation, operating and service instructions thoroughly before installing or servicing this equipment.

 **DANGER**

Copper wire suitable for at least 167°F (75°C) must be used for power connections.

 **DANGER**

The electrical power supply for this appliance must be the same as indicated on the rating and serial number plate located on the inside of the fryer door.

 **DANGER**

This appliance must be connected to the voltage and phase as specified on the ratings and serial number plate located on the inside of the fryer door.

 **WARNING**

Do not attach accessories to this fryer unless the fryer is secured from tipping. Personal injury may result.

 **WARNING**

Do not use water jets to clean this equipment.

 **WARNING**

This equipment is intended for indoor use only. Do not install or operated this equipment in outdoor areas.

 **DANGER**

Adequate means must be provided to limit the movement of this appliance without depending on or transmitting stress to the electrical conduit. A restraint kit is provided with the fryer. If the restraint kit is missing contact your local Frymaster Dean Factory Authorized Servicer (FAS) for part number 826-0900.

 **DANGER**

Prior to movement, testing, maintenance and any repair on your Frymaster fryer, disconnect all electrical power from the fryer.

 **DANGER**

The front ledge of the fryer is not a step. Do not stand on the fryer. Serious injury can result from slips or contact with the hot oil.

 **DANGER**

Do not store or use gasoline or other flammable vapors and liquids in the vicinity of this or any other appliance.

 **DANGER**

The crumb tray in fryers equipped with a filter system must be emptied into a fireproof container at the end of frying operations each day. Some food particles can spontaneously combust if left soaking in certain shortening material. Additional information can be obtained in the filtration manual included with the system.

 **WARNING**

No structural material on the fryer should be altered or removed to accommodate placement of the fryer under a hood. Questions? Call the Frymaster Dean Service Hotline at 1-800-551-8633.

 **WARNING**

Do not bang fry baskets or other utensils on the fryer's joiner strip. The strip is present to seal the joint between the frypot. Banging fry baskets on the strip to dislodge shortening will distort the strip, adversely affecting its fit. It is designed for a tight fit and should only be removed for cleaning.

2836 Series Electric Fryers Service & Parts Manual

TABLE OF CONTENTS

	Page #
1. SERVICE PROCEDURES	1-1
1.1 General	1-1
1.2 Replace Computer/Controller	1-1
1.3 Replace Interface Board	1-2
1.4 Replace Transformer	1-3
1.5 Replace Temperature Probe	1-3
1.6 Replace Heating Element	1-4
1.7 Replace High-Limit	1-6
1.8 Replace Frypot	1-6
1.9 Replace Contactor (Latching or Heating)	1-7
1.10 Built-in Filter System Service Procedures	1-7
1.11 Basket Lift Service Procedures	1-9
1.12 Electric Interface Board Diagnostic Chart	1-12
1.13 Probe Resistance Chart	1-13
1.14.1 Wiring Diagrams, Main 208/240V	1-14
1.14.2 Wiring Diagrams, Main 480V (120V Controls)	1-15
1.14.3 Wiring Diagrams, Main FP28DV/36 480V (120V Controls)	1-16
1.15 Wiring Diagrams, Modular Basket Lifts	1-17
1.16 Wiring Diagrams, 208/240V Systems With Built-in Filtration	1-18
1.16.1 Wiring Diagrams, 480V Systems With Built-in Filtration	1-19

2836 Series Electric Fryers Service & Parts Manual

TABLE OF CONTENTS (CONT.)

	Page #
2. PARTS LIST	2-1
2.1 Accessories	2-1
2.2 Basket Lift Assembly (Modular) and Related Components	2-2
2.3 Cabinetry and Related Components	2-5
2.3.1.1 F228 Cabinetry	2-5
2.3.1.2 F128/136 Cabinetry	2-7
2.3.1.3 F128/236 Cabinetry	2-9
2.3.2 Door Components	2-11
2.3.3 Dump Station Components	2-12
2.4 Computer and Related Components	2-13
2.5 Contactor and Power Cord Box Assembly	2-14
2.6 Terminal Block Mount Assembly	2-16
2.7 Component Box Assembly	2-17
2.8 Filter Pan and Related Components	2-19
2.9 Frypot and Related Components	2-20
2.9.1.1 Frypot and Drain Valve Components	2-20
2.9.1.2 Drain Components	2-21
2.10 Elements and Related Components	2-22
2.11 Oil Disposal Wand	2-24
2.12 Oil Return Assembly	2-25
2.13 Filter Pump Assembly	2-27
2.14 Wiring Harnesses and Cables	2-28
2.15 Fasteners	2-27
2.16 Connectors	2-30

2836 SERIES ELECTRIC FRYERS

CHAPTER 1: SERVICE PROCEDURES

FINDING YOUR WAY AROUND THE 2836 SERIES FRYER

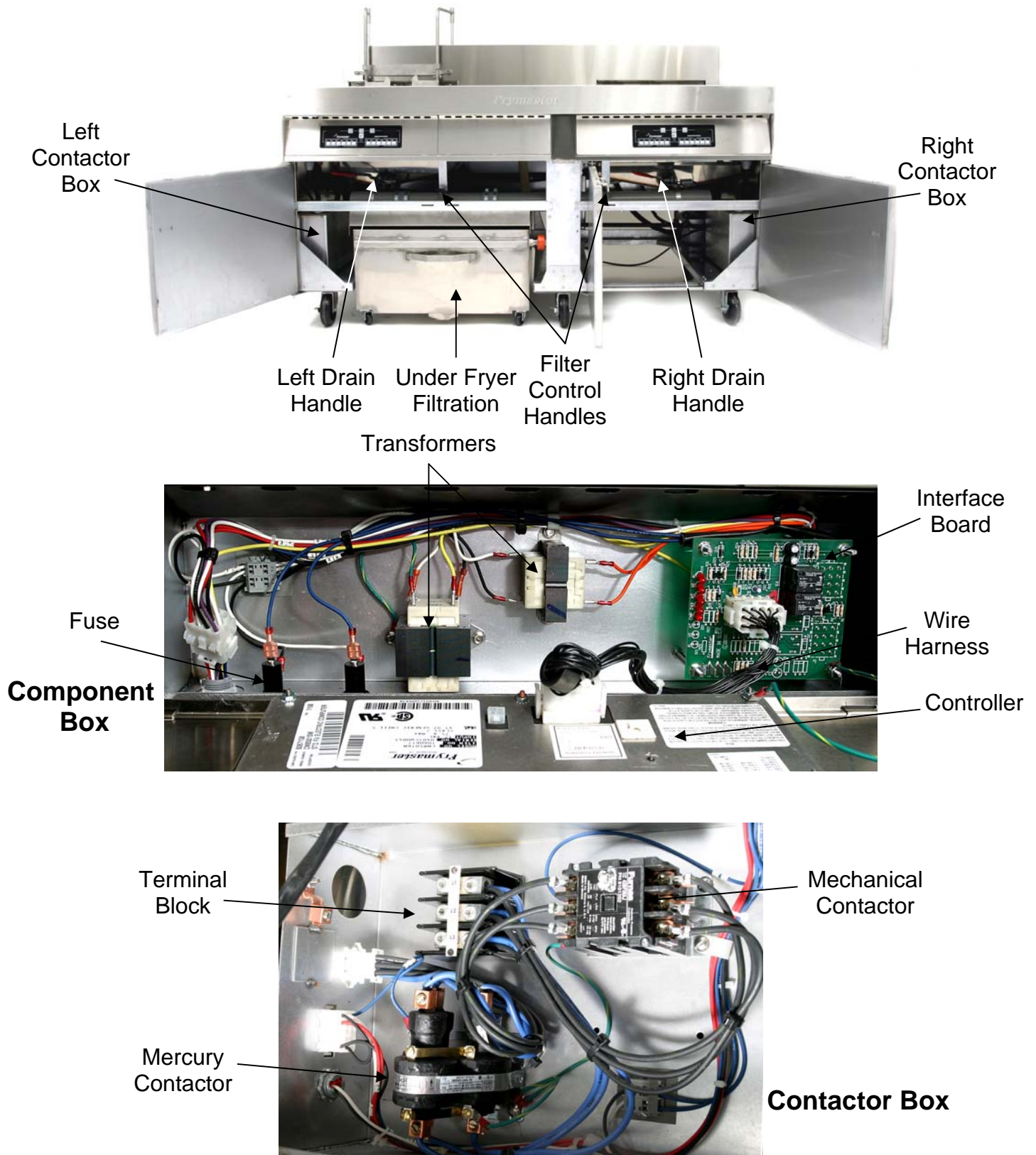

1.1 General

Before performing any maintenance on your Frymaster Dean 2836 Series Electric fryer, you must disconnect the electrical power supply.

When electrical wires are disconnected, it is recommended that they be marked in such a way as to facilitate reassembly.



Hot oil will cause severe burns. Never attempt to move this appliance when filled with hot oil, or to transfer hot oil from one container to another.



This equipment should be unplugged when servicing, except when electrical circuit tests are required. Use extreme care when performing such tests.

This appliance may have more than one electrical power supply connection point. Disconnect all power cords before servicing.

Inspection, testing and repair of electrical components should be performed by an authorized service agent only.

1.2 Replace Computer/Controller

1. Unscrew and remove two control panel screws on control panel front. Swing the panel open from the top.
2. Unplug wiring harness at plug on back of controller. Unplug controller ground wire from controller.
3. Remove the control panel/controller by lifting the assembly from the hinged slots in the control-panel frame.
4. Reverse procedures to install new controller.

1.3 Replace Interface Board

1. Unplug all power cords. Perform Procedure 1.2, Steps 1-4, Replace Computer/Controller.
2. Unplug wire harness from the interface board. Remove all wiring from the terminals of the interface board, ensuring that each wire is marked for reattachment.
3. Remove the nuts from each corner of the interface board and slide the board from the studs. Unplug connectors J1 and J2, mark and unplug all other wiring on rear of the interface board. Ensure that standoffs remain in place on studs prior to installing new interface board. Install the new interface board by reversing the previous procedures.

4. Ensure that wire harnesses are connected to back of interface board prior to securing interface board. Also, ensure that wiring and wire harnesses are connected to the proper terminals.

1.4 Replace Transformer

1. Unplug all power cords. Perform Procedure 1.2, Steps 1-4, Replace Computer/Controller.
2. Hold new transformer up to old transformer to be replaced and disconnect one wire at a time from old and connect to new.
3. Remove the screws that secure the transformer to the component box.
4. Install the new transformer by reversing the preceding procedures. Make sure you reconnect the wiring to the proper terminals and the harnesses to the correct connectors.

1.5 Replace Temperature Probe

1. Unplug fryer from the electrical source.
2. Drain the cooking oil from the frypot.
3. Remove the fryer from the exhaust hood to gain access to the rear of the fryer.
4. If unit is equipped with modular basket lift, remove basket lift assembly and set aside.
5. Remove the screws from the top cap and back cover(s). Set the cover(s), top cap and screws aside.
6. Disconnect the wire harness containing the probe wiring. It may be necessary to remove the wire ties.
7. Use a pin-pusher (P/N 806-4855 or P/N 807-0928) to remove the red and white probe wires from the connector. Note probe pin location in plug. Pull the probe wires out of the insulation.
8. Remove the screw(s) securing the probe bracket to the element. Remove the metal wraps securing the probe to the element.

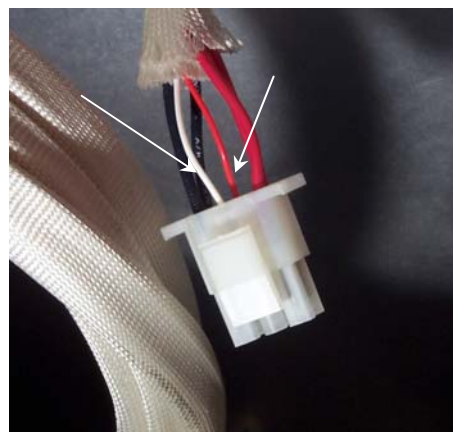

Use a pin-pusher to remove probe wires from connector (arrows).

9. Remove the probe bracket and the securing components from the probe bulb and element. Thread the probe wire through the hole in the tilt plate assembly and remove the probe.
10. Thread the new probe wire through the hole in tilt plate. Place the new temperature probe assembly onto the element and secure with the bracket and screws removed earlier. Clip the probe onto the rear of the element in two places. The temperature probe assembly should be oriented in the same manner as the probe being replaced.
11. Thread the probe wires into the harness insulation. Note the pin positions and insert pins in the connector. Reconnect the harness and secure with a wire-tie.
12. Lower the element into the frypot with the lift handle.
13. Install the back covers, basket lift assembly, and top cap and secure with screws.

1.6 Replace Heating Element

1. Perform Procedure 1.5, Replace Temperature Probe, Steps 1-7.
2. Unplug the element connectors for the element being removed (right element- 6-pin harness connector; left element- 9-pin harness connector). Remove the element wires from the connector. Press down on either side of the connector while pulling up on the top portion. The connector will open from the top. Note wiring configuration in connector before removing element wire pins. Pull all wires from the connector.

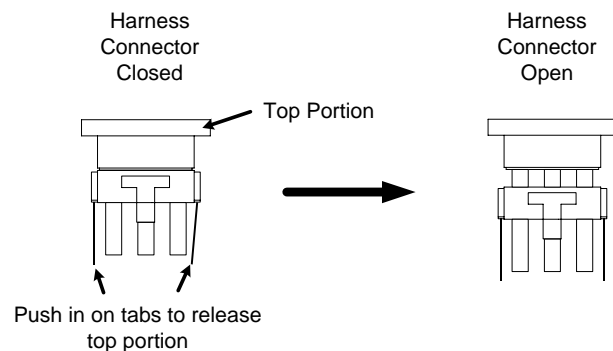

3. Loosen conduit connector and pull element wires through conduit.
4. Remove the screws securing the temperature probe bracket from the element. Remove the probe clamp (metal wire-wrap). Set the temperature probe and probe-securing components aside.



Loosen connector here.

NOTE: Temperature probe removal is not required if the left element is being replaced.

5. Disconnect the element springs from the tilt brackets.
6. Remove the element clamps and hardware before removing mounting-screws and nuts on the defective element. Remove all wire-ties securing element wiring, and then remove element from frypot.

7. Install the replacement element in the frypot and secure with the mounting hardware.
8. Reinstall the temperature probe and probe-bracket components onto the replacement element.
9. Route the element leads (terminals) to the rear of the fryer
10. Secure element wiring with wire-ties.

11. Route the element wires through the conduit and tighten conduit connector.

11. When replacing the left element (as viewed from the rear of the fryer), use the 9-pin connector, inserting the leads from the replacement element. Ensure the pin numbers match the numbers of the defective element wires. When all pin terminals have been fully inserted, close the connector by sliding the halves together until the tabs snap back into place (reverse procedure in this section, Step 2). Check wire numbers to ensure correct wiring of the replacement element.

When replacing the right element (as viewed from the rear of the fryer), follow the above procedure, inserting pin terminals into the corresponding holes in the 6-pin connector.

12. Connect the connectors, ensuring the latches lock in place.
13. Install the temperature probe wires (marked for re-assembly) in the corresponding pin locations.
14. Reconnect the element springs to the tilt brackets
15. Install the back covers, basket lift assembly, and top cap and secure with screws.
16. Position fryer under exhaust hood.

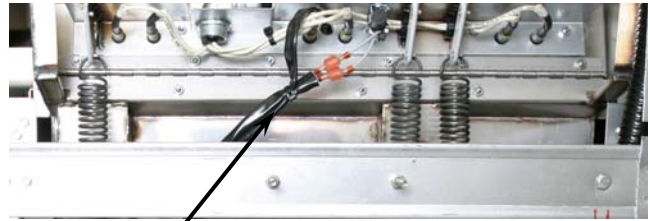

Ensure that the wires are properly routed and secured.

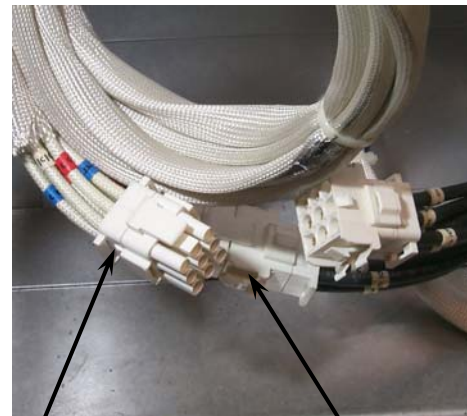

Left Element—
9-Pin Connector

Right Element—
6-Pin Connector

1.7 Replace High-Limit

1. Perform Procedure 1.5, Replace Temperature Probe, Steps 1-4.
2. Disconnect the wire harness containing the high-limit wires.
3. Use a pin-pusher (P/N 806-4855 or P/N 807-0928) to remove the two high-limit wires from the wire harness connector (arrows). Note pin location in connector before removing wires.
4. Remove the high-limit from the frypot using an open-end wrench or other suitable tool.
5. Apply Loc-Tite PST 567 sealant to the replacement high-limit threads.
6. Screw the replacement high-limit into the frypot and tighten to 170-180 inch-pounds torque. DO NOT OVERTIGHTEN.
7. Insert the replacement high-limit wires into the connector, ensuring each wire is in the correct hole..
8. Reconnect the high-limit wire-harness connector.
9. Install and secure the back cover(s).
10. Return fryer to operation.

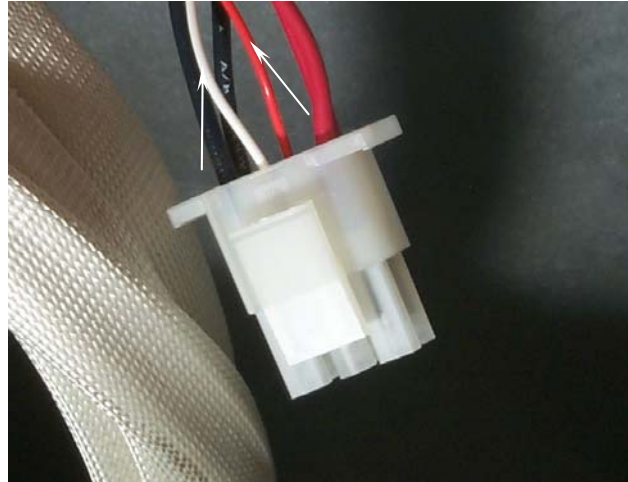

Using a pin-pusher, remove two high-limit wires (arrows) from connector.



Place wrench here when removing and installing high-limit.

1.8 Replace Frypot

1. Perform Procedure 1.5, Replace Temperature Probe, Steps 1-7.
2. Perform Procedure 1.2, Replace Computer/Controller, Steps 1-3.
3. Perform Procedure 1.7, Replace High-Limit, Steps 1-4.
4. Disconnect the element wire harnesses.
5. If the fryer has a built-in filtration system, remove all the plumbing from the frypot, including oil-return and drain plumbing.

6. Remove the screws securing the frypot to the front frame of the fryer.
7. Carefully lift the frypot from the cabinet.
8. Remove the drain valve from the old frypot and install on the new frypot.
9. Apply Loc-Tite Sealant PST 567 to the high-limit threads. Install high-limit into the new frypot.
10. Disconnect the tilt plate springs from the old frypot.
11. Remove the securing screws from the tilt plate. Lift the tilt plate/heating element assembly from the old frypot and install on the new frypot.
12. Follow the preceding steps in reverse to install the new frypot into the fryer.
13. NOTE: Apply Loc-Tite Sealant PST 567 to all pipefittings prior to installation.

1.9 Replace Contactor (Latching or Heating)

1. Remove filter pan.
2. Remove cover to contactor box.
3. Identify faulty contactor. Remove all wiring connected to the contactor terminals inside the component box. Tape wire-pairs together and mark each wire-set or wire for reassembly.
4. Remove contactor-mounting screws and remove the contactor.
5. Install the new contactor and connect the wiring removed in Step 3.

1.10 Built-in Filter System Service Procedures

Troubleshooting Built-In Filtration Systems

One of the most common errors is placing the filter paper on the bottom of the filter pan rather than over the filter screen.



Ensure that the paper support screen is in place prior to filter paper placement and filter pump operation. Improper screen placement is the major cause of filter system malfunction.

Whenever the complaint is "the pump is running, but no oil is being filtered", check the installation of the filter paper, and ensure that the correct size is being used.

If the pump motor overheats, a circuit breaker will trip and the motor will not start until the breaker is reset. If the pump motor does not start, press the white reset button located under the component box, inside the cabinet.

If the pump starts after resetting the breaker, then something is causing the motor to overheat. A major cause of overheating is when several frypots are filtered sequentially, thus overheating the pump and motor. Allow the pump motor to cool at least 30 minutes before resuming operation, and allow time for the motor to cool between sequential frypot filtering.

Pump overheating can be caused by:

- Solidified shortening in the pan or filter lines,
- or
- Attempting to filter unheated oil or shortening.

Cold oil and shortening are more viscous, causing the pump motor to overheat. Always filter with the oil or shortening at operating temperature [350°F (177°C)].

If the motor runs but the pump does not, there is a blockage in the pump. Incorrectly sized or installed paper/pads will allow food particles and sediment to pass through the filter pan and into the pump. When sediment enters the pump, the gears bind, causing the motor to overload, again tripping the thermal overload. Solidified shortening in the pump will also cause it to seize, with the same problem.

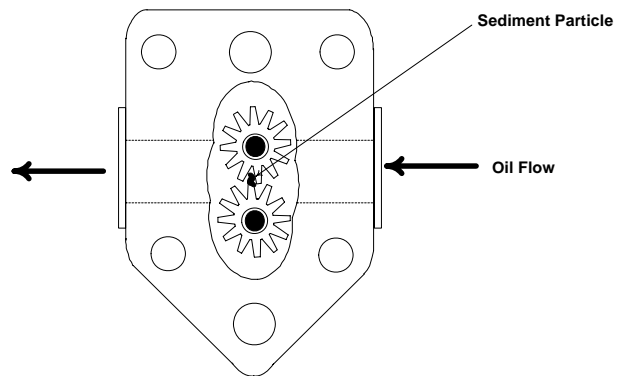

A pump seized by debris or hard shortening can usually be freed by manually moving the gears with a screwdriver or other instrument.

Disconnect power to the filter system, remove the input plumbing from the pump, and use a screwdriver to manually turn the gears.

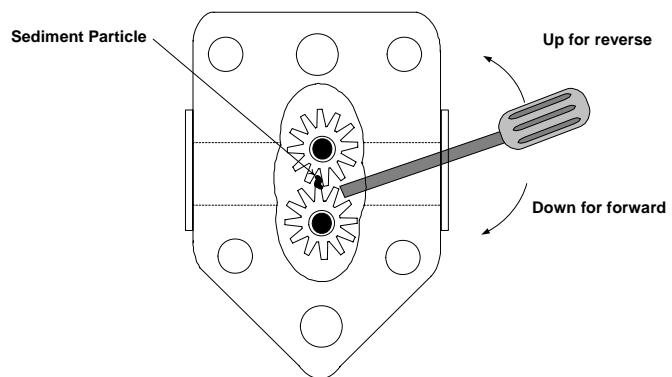

- Turning the pump gears in reverse will release a hard particle.
- Turning the pump gears forward will push softer objects and solid shortening through the pump and allow free movement of the gears.

Incorrectly sized or installed paper/pads allows food particles and sediment to pass through and clog the suction tube on the bottom of the filter pan. Particles large enough to block the suction tube may indicate that the crumb tray is not being used. Pan blockage can also occur if shortening is left in the pan and allowed to solidify. Blockage removal can be accomplished by forcing the item out with an

auger or drain snake. Compressed air or other pressurized gases should not be used to force out the blockage

1.11 Basket Lift Service Procedures

2836 Series Electric fryers may optionally be equipped with automatic basket lifts to ensure uniform cooking times. Electric fryers can be equipped with "modular" or "bell-crank" basket lifts.

A **modular basket lift** (illustrated) consists of a toothed rod to which the basket lift arm is attached, a reversible-drive gear motor and a pair of roller-activated microswitches. The gear motor engages the teeth of the rods, moving them up or down, depending upon the motors' direction. The microswitches at the upper and lower limits of movement stop the motor when the basket is in the full up or full down position.

Timing circuitry in the controller initiates and stops basket lift operation depending upon the variables programmed by the operator. When the product button is pressed, the timing circuitry activates a coil in the basket lift relay to supply power to the lower microswitch. The microswitches stop the motor at the lift's upper and lower travel limits and reverse the direction of current flow, thus reversing the motor direction.

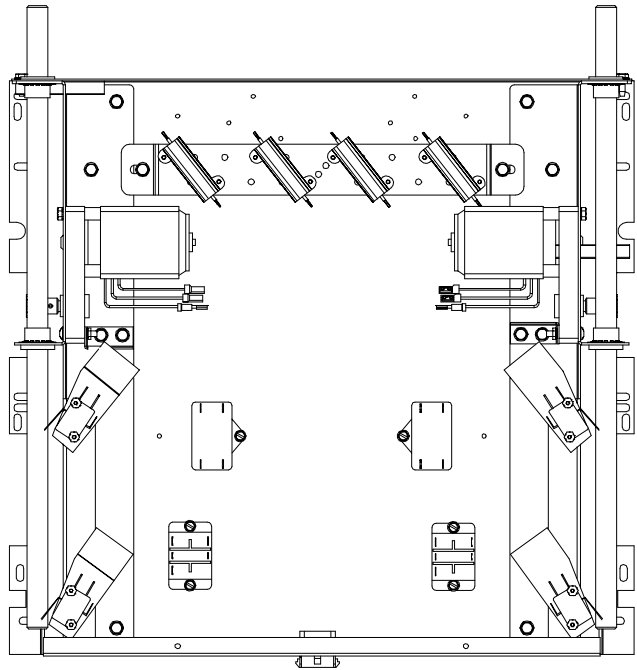

Modular Basket Lift Assembly (Typical).

Simplified Schematic

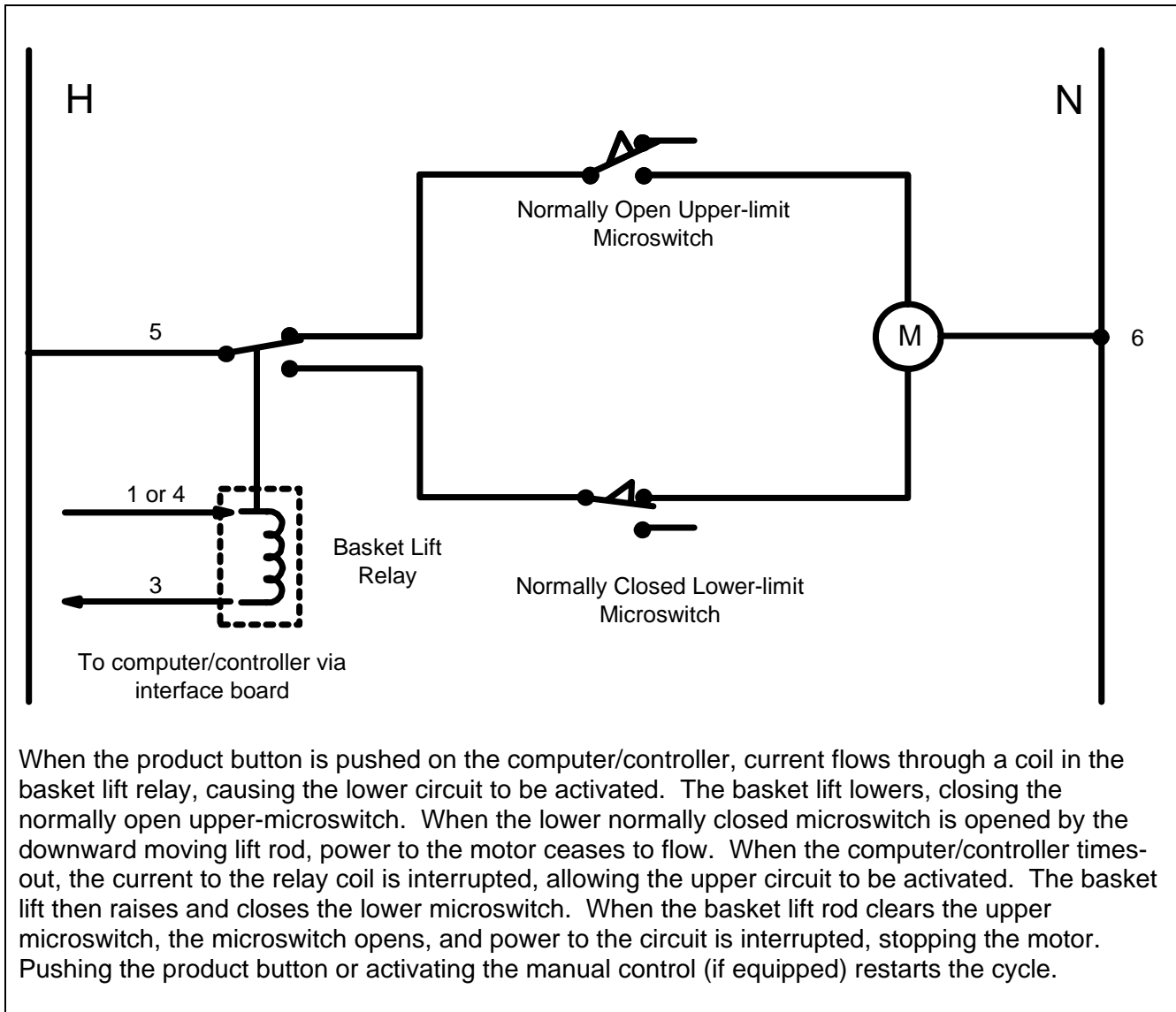

When the product button is pushed on the computer/controller, current flows through a coil in the basket lift relay, causing the lower circuit to be activated. The basket lift lowers, closing the normally open upper-microswitch. When the lower normally closed microswitch is opened by the downward moving lift rod, power to the motor ceases to flow. When the computer/controller times-out, the current to the relay coil is interrupted, allowing the upper circuit to be activated. The basket lift then raises and closes the lower microswitch. When the basket lift rod clears the upper microswitch, the microswitch opens, and power to the circuit is interrupted, stopping the motor. Pushing the product button or activating the manual control (if equipped) restarts the cycle.

Problems with the modular basket lift design can be grouped into three categories:

- Binding/jamming problems
- Motor and gear problems
- Electronics problems

BINDING/JAMMING PROBLEMS

Noisy, jerky or erratic movement of the lifts is usually due to lack of lubrication of the rods and their bushings. Apply a light coat of Lubriplate or similar lightweight white grease to the rod and bushings to correct the problem.

With the modular basket lift, another possible cause of binding is improper positioning of the motor, which prevents the gear from correctly engaging the teeth in the rod. To correct the problem, loosen the screws that hold the motor in place and move it forward or backward until the rod has just enough slack to be rotated slightly.

MOTOR AND GEAR PROBLEMS

With the modular basket lift, the most likely problem to be encountered in this category is erratic motion of the lift due to a worn drive gear. Failure to keep the lift rod and bushings properly lubricated will cause unnecessary wear of the gear. The problem is corrected by replacing the worn gear.

If the lift cycles correctly but fails to remain in the up position (i.e., goes up, but then slowly settles back down into the frypot), the problem is a failed motor brake. The motor must be replaced.

If power is reaching the motor but the motor fails to run, the motor is burned out and must be replaced.

ELECTRONICS PROBLEMS

Within this category are problems associated with the relays, microswitches, capacitors, resistors, interface board, wiring, and controls. The most common problem in this category is a lift that continuously travels up and down. This is usually caused by a microswitch that is out of adjustment.

Troubleshooting the electronics of a modular-type basket lift is simply a process of verifying current flow through the individual components up to and including the motor. Using a multimeter set to the 250 VAC range, check the connections on both sides of the component for the presence of the applied line voltage. The accompanying simplified wiring diagrams identify the components and wiring connection points.

1.12 Electric Interface Board Diagnostic Chart

The following diagram and charts provide ten quick system checks that can be performed using only a multimeter.

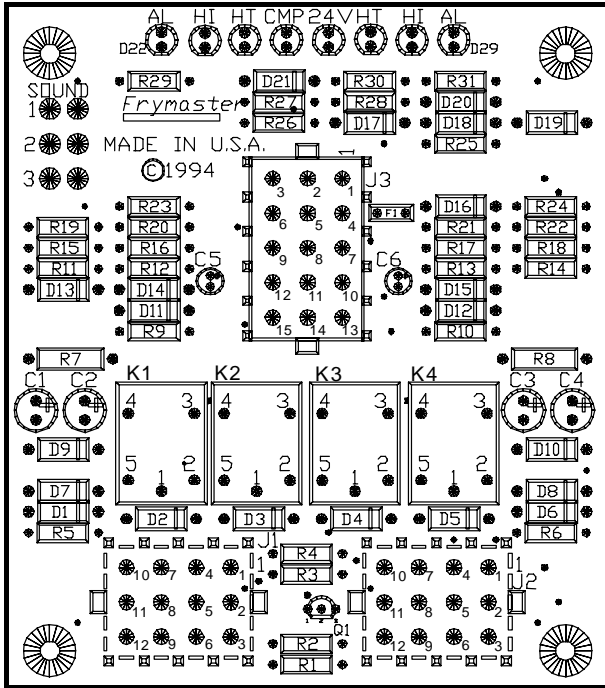

Note: The sealed relays are replaceable. If a relay fails, the replacement part number is 807-3932.

Diagnostic LED Legend

CMP indicates power from 12V transformer
24 indicates power from 24V transformer
HI (RH) indicates output (closed) from right latch relay
HI (LH) not applicable to Ultimate Electric fryers
HT (RH) indicates output from right heat relay
HT (LH) not applicable to Ultimate Electric fryers
AL (RH) indicates output (open) from right latch relay
AL (LH) not applicable to Ultimate Electric fryers

Meter Setting	Test	Pin	Pin	Results
12 VAC Power	50 VAC Scale	1 of J2	3 of J2	12-16 VAC
24 VAC Power	50 VAC Scale	2 of J2	Chassis	24-30 VAC
*Probe Resistance	R X 1000 OHMS	11 of J2	12 of J2	See Chart
Hi-Limit Continuity	R X 1 OHMS	7 of J2	4 of J2	0 - OHMS
Latch Contactor Coil	R X 1 OHMS	8 of J2	Chassis	3-10 OHMS
Heat Contactor Coil	R X 1 OHMS	9 of J2	Chassis	18-25 OHMS

***Disconnect 15-Pin harness from the computer/controller before testing the probe circuit.**

1.13 Probe Resistance Chart

Use the chart below when testing temperature probes and probe circuits for proper operation.

Probe Resistance Chart																	
F	OHMS	C	F	OHMS	C	F	OHMS	C	F	OHMS	C	F	OHMS	C	F	OHMS	C
60	1059	16	130	1204	54	200	1350	93	270	1493	132	340	1634	171			
65	1070	18	135	1216	57	205	1361	96	275	1503	135	345	1644	174			
70	1080	21	140	1226	60	210	1371	99	280	1514	138	350	1654	177			
75	1091	24	145	1237	63	215	1381	102	285	1524	141	355	1664	179			
80	1101	27	150	1247	66	220	1391	104	290	1534	143	360	1674	182			
85	1112	29	155	1258	68	225	1402	107	295	1544	146	365	1684	185			
90	1122	32	160	1268	71	230	1412	110	300	1554	149	370	1694	188			
95	1133	35	165	1278	74	235	1422	113	305	1564	152	375	1704	191			
100	1143	38	170	1289	77	240	1432	116	310	1574	154	380	1714	193			
105	1154	41	175	1299	79	245	1442	118	315	1584	157	385	1724	196			
110	1164	43	180	1309	82	250	1453	121	320	1594	160	390	1734	199			
115	1174	46	185	1320	85	255	1463	124	325	1604	163	395	1744	202			
120	1185	49	190	1330	88	260	1473	127	330	1614	166	400	1754	204			
125	1195	52	195	1340	91	265	1483	129	335	1624	168	405	1764	207			

1.14.1 Wiring Diagrams, Main – 208/240V

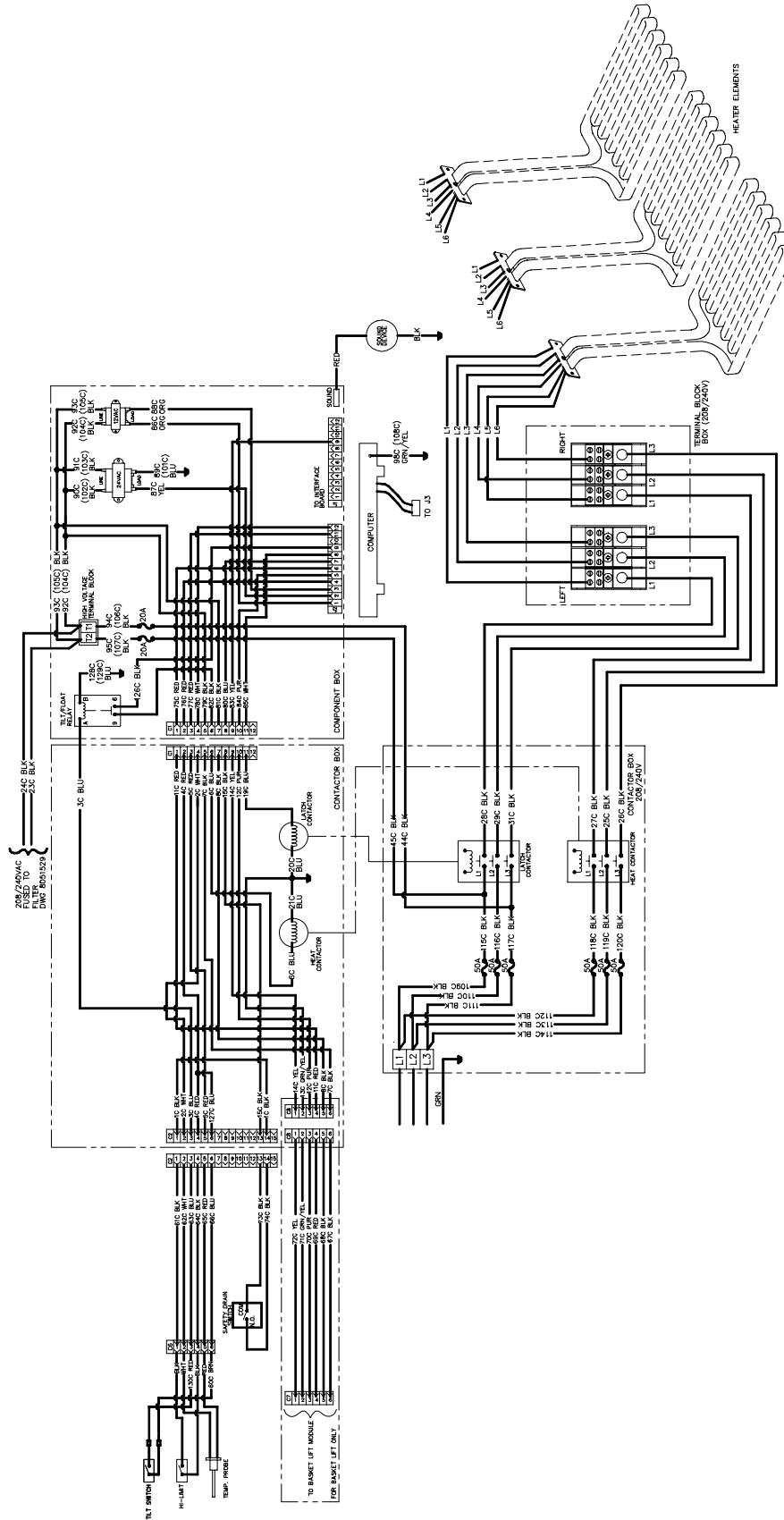

8051548A

1.14.3 Wiring Diagrams, Main FP28DV/36 480V (120 V Controls)

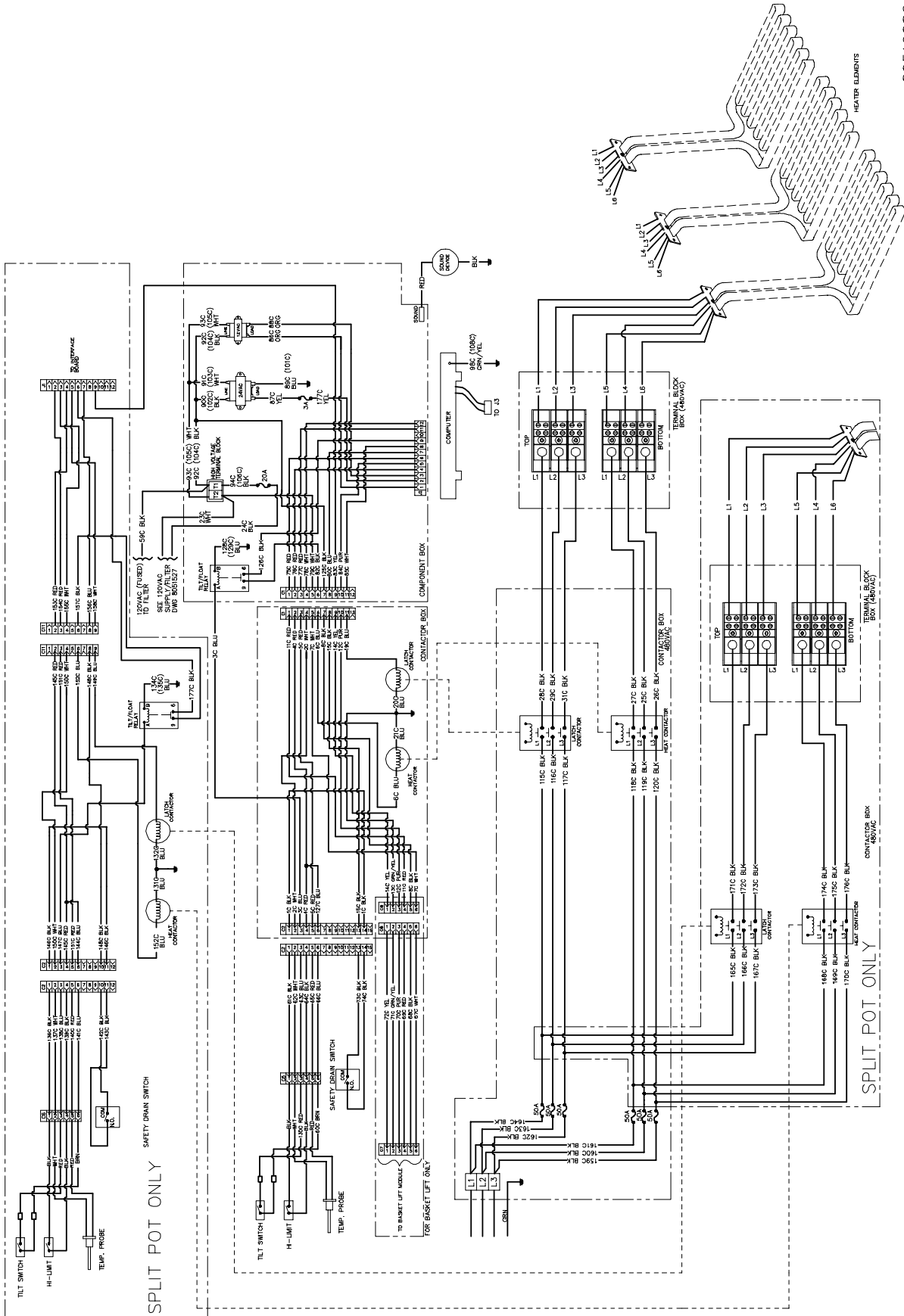

8051608C

1.16.1 Wiring Diagrams: 208/240V Systems With Built-in Filtration

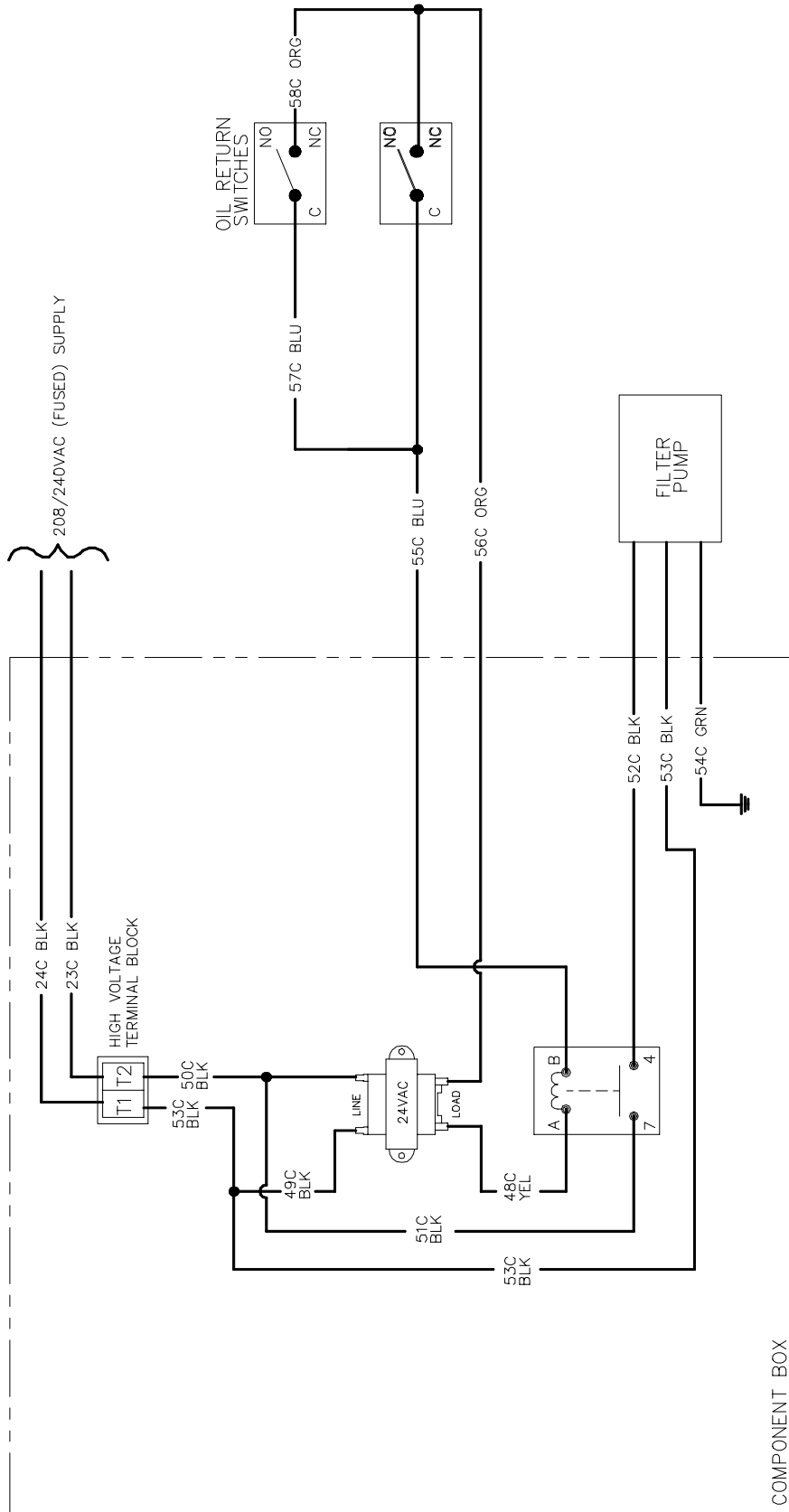

8051529D

1.16.2 Wiring Diagrams: 480V Systems With Built-in Filtration

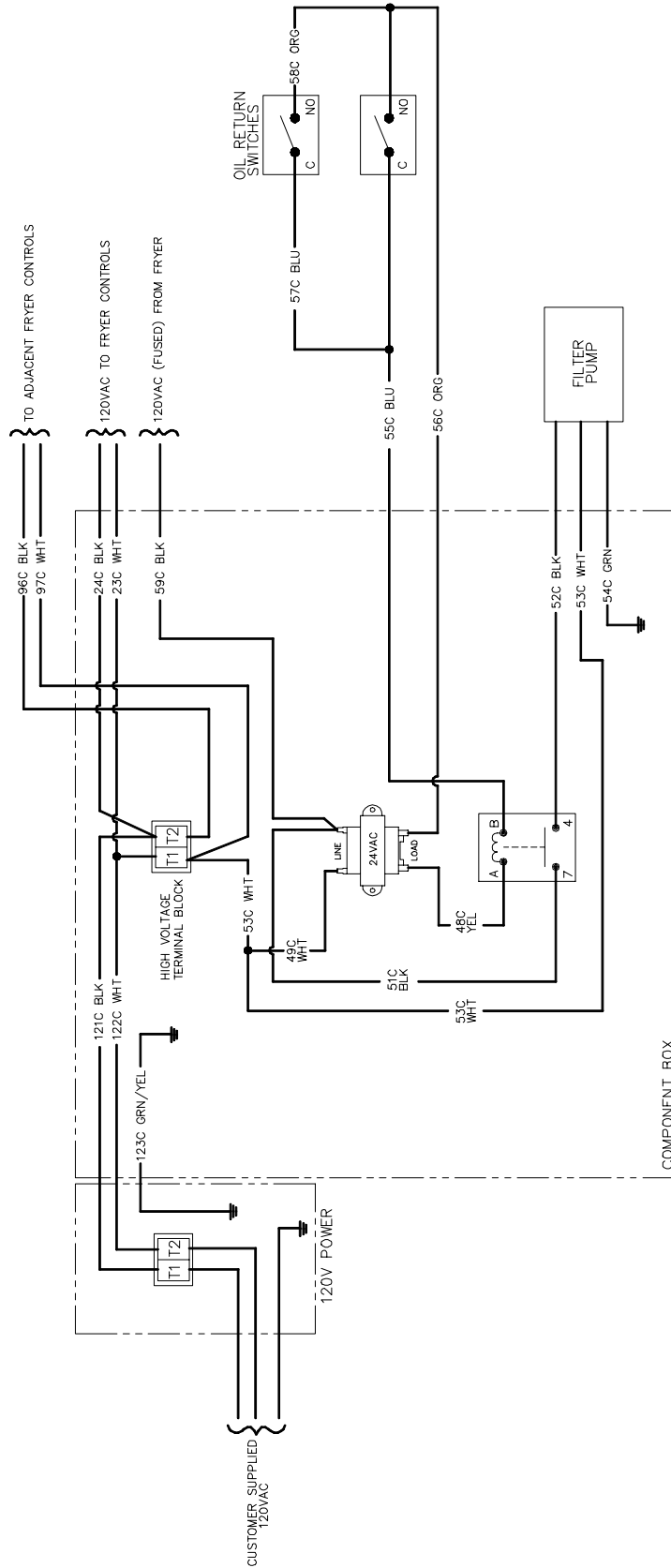

8051527C

2836 SERIES ELECTRIC FRYERS

CHAPTER 2: PARTS LIST

2.1 Accessories

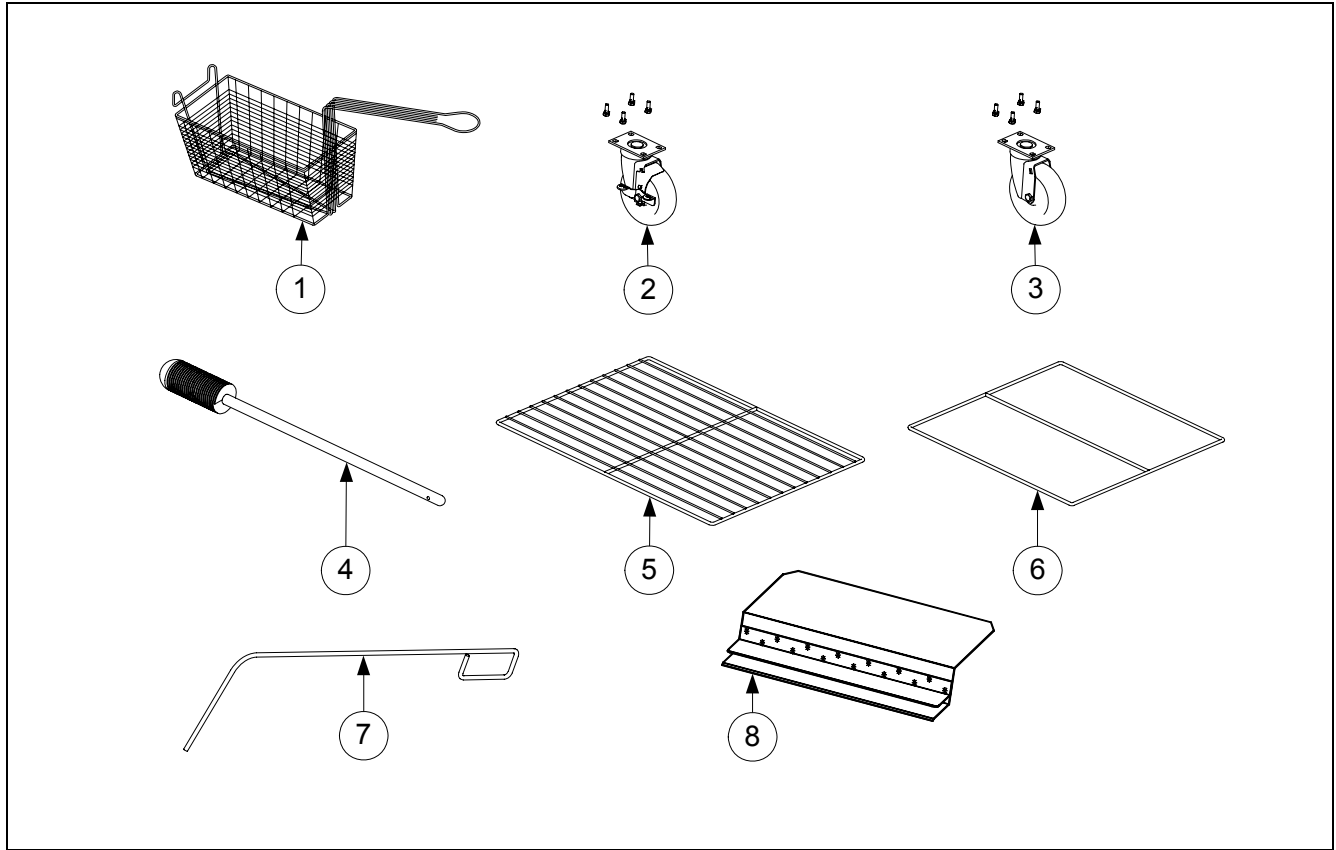

Item	Part Number	Description
1	803-0306	Fry Basket, Twin Basket
*	230-4267	Basket Hanger, 36
2	826-1118	Caster, 5" - With Brake (Mounting Hardware Included)
3	826-1117	Caster, 5" - W/O Brake (Mounting Hardware Included)
4	803-0398	Brush, Frypot
5	803-0381	Rack, FP36 Basket Support
	803-0349	Rack, FP28 Basket Support
	803-0363	Rack, FP14 (FP28DV) Basket Support
6	803-0350	Screen Assembly, FP28/36 Dump Station
7	803-0197	Fryer Friend 27" Cleanout Rod
*	803-0059	Scoop, Fish with plastic coated handle
*	108-2162	Cover, Frypot DV
*	108-2163	Cover, Frypot, FV 36
*	108-2164	Cover, Frypot, FV 28
8	823-4957	Splash Guard, Right
	823-4961	Splash Guard, Left
*	823-4636	Connecting Strip, FP28/36
*	823-5679	Connecting Strip, FP14 (FP28DV)
*	803-0293	Glove, Hot Oil Neoprene (pair)
*	803-0002	Filter Powder – 80 Individual Packages
*	803-0303	Filter Paper –100 sheets

* Not Illustrated

2.2 Basket Lift Assembly (Modular) and Related Components

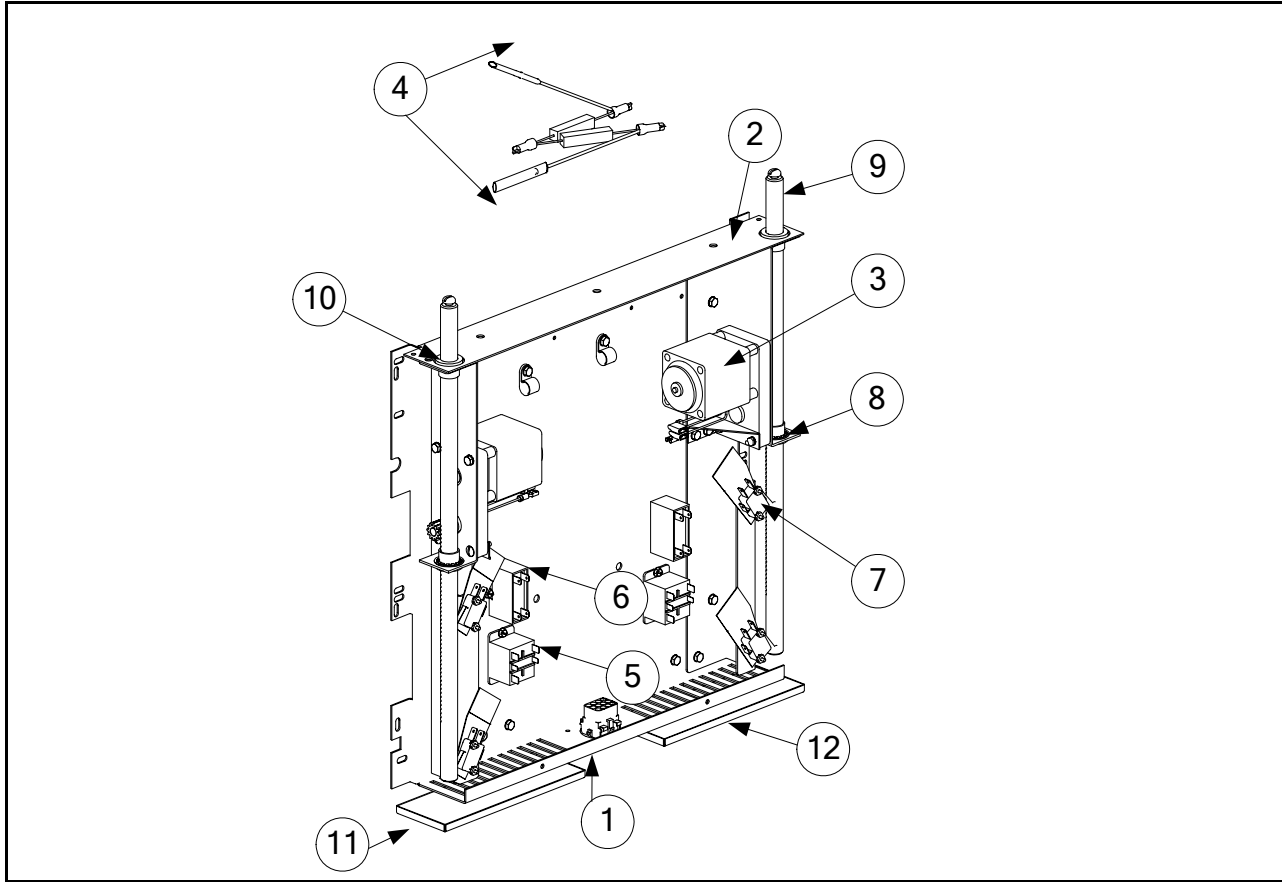

Item	Part Number	Description
	106-3775	Basket Lift, Modular Assembly 100-120V with Relay
1	807-0158	Connector, 6-Pin
2	200-6455	Mount, Modular Basket Lift
3	806-5964SP	Motor Assembly, Modular 120V Basket Lift
4	806-8530SP	Resistor Assembly, 120V
*	106-2770SP	Resistor Assembly, 200/208/220V
*	106-2771	Resistor Assembly, 230/240/250V
*	807-2661	Resistor, 13 Ohm -120V, 10W (Part of 806-8530 Assembly)
*	807-3893	Resistor, 50 Ohm, 50W (Part of 106-2770: 200-208V Assembly)
*	807-3893	Resistor, 50 Ohm, 50W (Part of 106-2771: 230-250V Assembly)
5	807-1683	Relay, 12 VDC
6	807-2513	Capacitor, Motor Run 12.5 MFD 250 VAC
7	807-2572	Microswitch, Formed End
8	809-0082	Ring, 3/4" Truarc ZP
9	810-1012	Rod, Modular Basket Lift
10	813-0035	Bushing, Bronze Bunting .641/.640 ID
11	824-1351	Basket Lift Drip Pan
12	824-1353	Basket Lift Drip Pan
*	WIR0597	Wire Assembly, FP28/36S Mod Bb 120V

* Not Illustrated

2.2 Basket Lift Assembly (Modular) and Related Components (cont.)

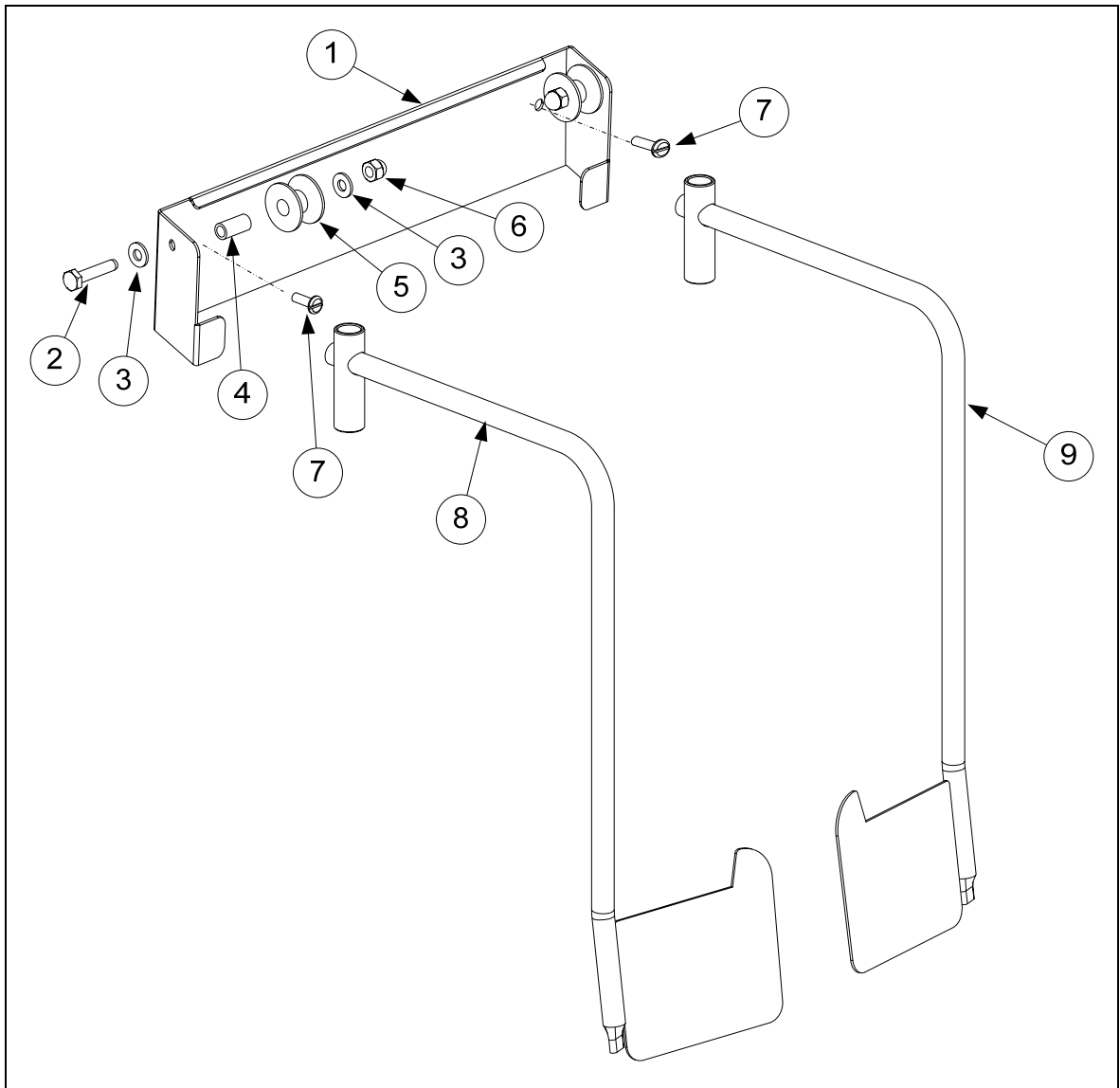

Item	Part Number	Description
	106-4312	Roller Assembly FV (Use 106-5958 for DV)
1	210-8091	Bracket FV (use 230-0083 for Bracket FP28DV)
2	809-0508	Bolt, 1/4" - 20 x 1-1/4" Hex Head S/S
3	809-0190	Washer, Flat- 1/4" S/S
4	810-0374	Spacer, Tubular Basket Lift Roller
5	810-0194	Roller, Basket Lift
6	809-0990	Nut, Acorn - 1/4" - 20 S/S
7	809-0402	Screw, 1/4" - 20 x 1/2" Round Slotted S/S
8	823-7235	Basket Lift Arm- Left
9	823-7236	Basket Lift Arm- Right

2.3 Cabinetry and Related Components

2.3.1.1 FP228 Cabinet and Related Components

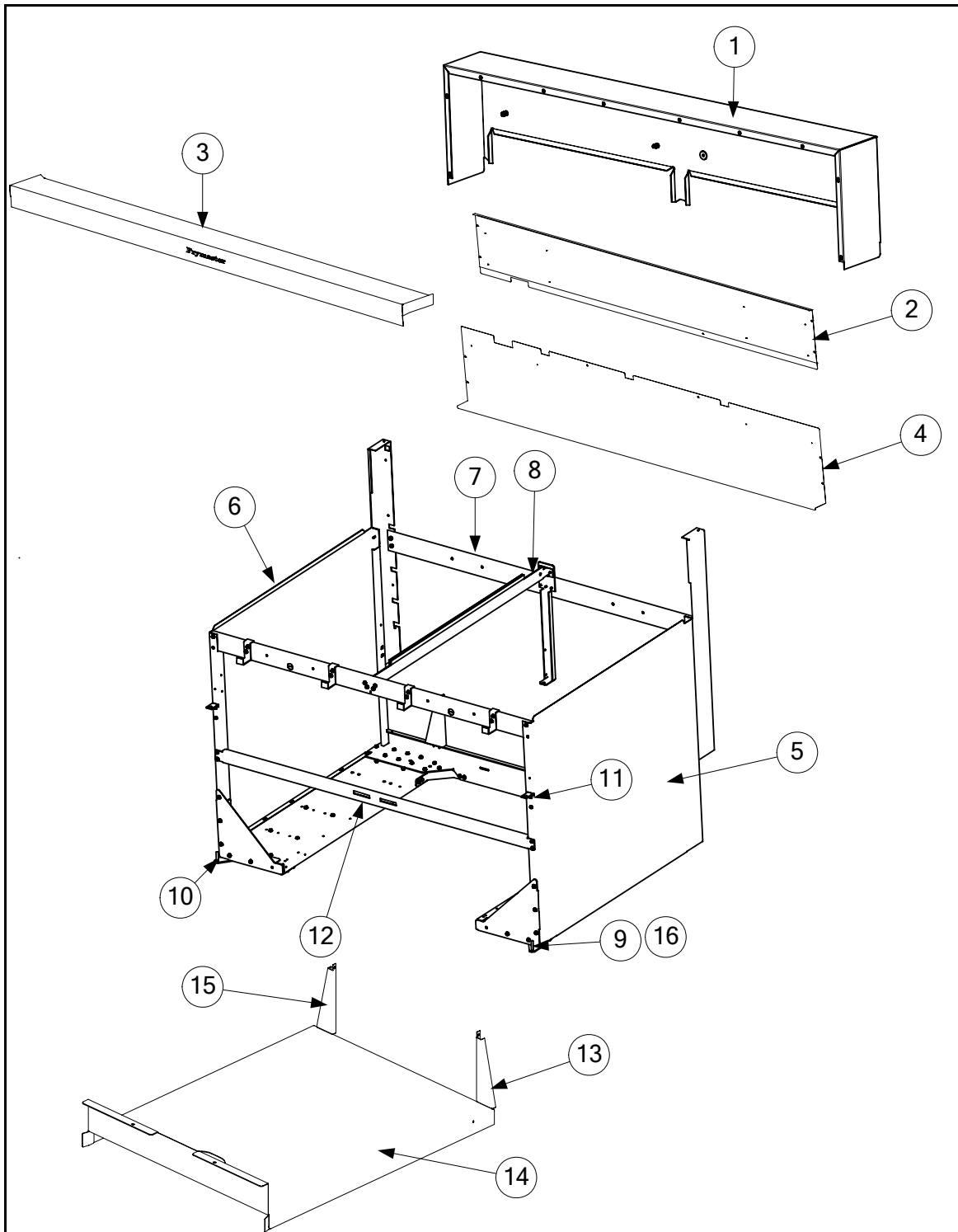

2.3.1.1 FP228 Cabinet and Related Components (cont.)

Item	Part Number	Description
	106-3589	Cabinet Assembly, FP228
1	823-6483	Tilt Housing Assembly, FP228
2	200-6300	Upper Back
3	106-3668	Top Cap Assembly, FP228
4	200-6301	Lower Back
5	212-8234	Cabinet Side, Right
6	211-8234	Cabinet Side, Left
7	200-6009	Cabinet Support, Rear
8	200-6008	Cabinet Divider
9	823-4811	Hinge, Lower Right
10	823-4810	Hinge, Lower Left
11	810-1508	Hinge, Upper Universal
*	230-7192	Hinge, Lower, Universal
12	810-2346	Magnet, Door
13	202-6593	Bracket, Filter Pan Cover Mounting, Right
14	823-7237	Lid, Filter Pan
15	201-6593	Bracket, Filter Pan Cover Mounting, Left
16	200-6376	Plate, FP28/36 Door Hinge Mount

* Not Illustrated

2.3.1.2 FP128/136 Cabinet and Related Components

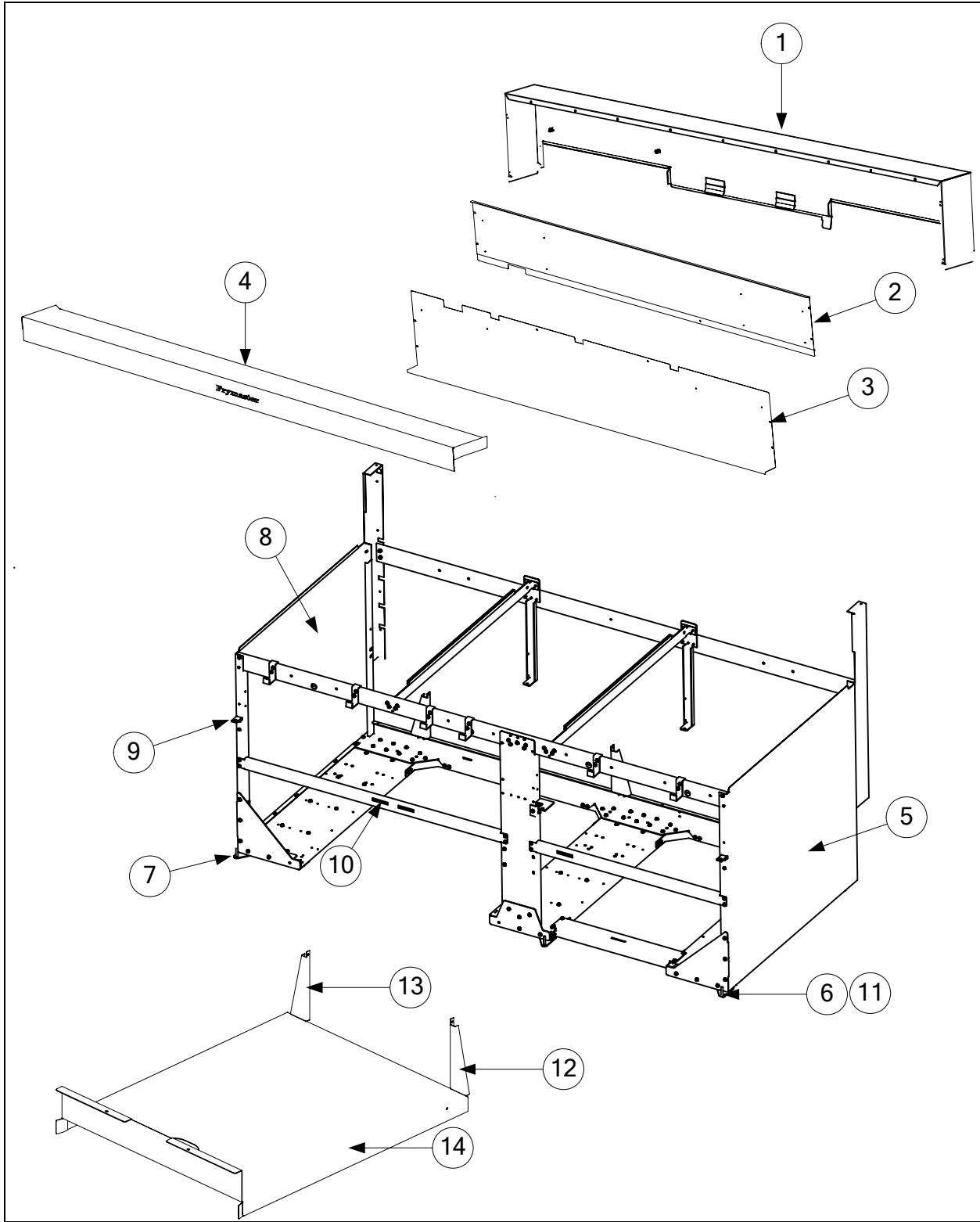

2.3.1.2 FP128/136 Cabinet and Related Components (cont.)

Item	Part Number	Description
	106-3625	Cabinet Assembly FP128/136
1	106-3750	Tilt Housing Assembly, FP128/136
2	200-6298	Upper Back Cabinet
3	200-6299	Lower Back Cabinet
4	106-3704	Top Cap Assembly, FP128/136
5	212-8234	Cabinet Side, Right
6	230-4998	Hinge, Lower Right
7	823-4810	Hinge, Lower Left
*	210-6343	Door hinge, upper
*	230-7192	Door hinge, lower
8	211-8234	Side, Left
9	810-1508	Hinge, Upper Universal
10	810-2346	Magnet, Door
11	200-6376	Plate, FP28/36 Door Hinge Mount
12	202-6593	Bracket, Filter Pan Cover Mounting, Right
13	201-6593	Bracket, Filter Pan Cover Mounting, Left
14	823-7237	Lid, Filter Pan

* Not Illustrated

2.3.1.3 FP128/236 Cabinet and Related Components

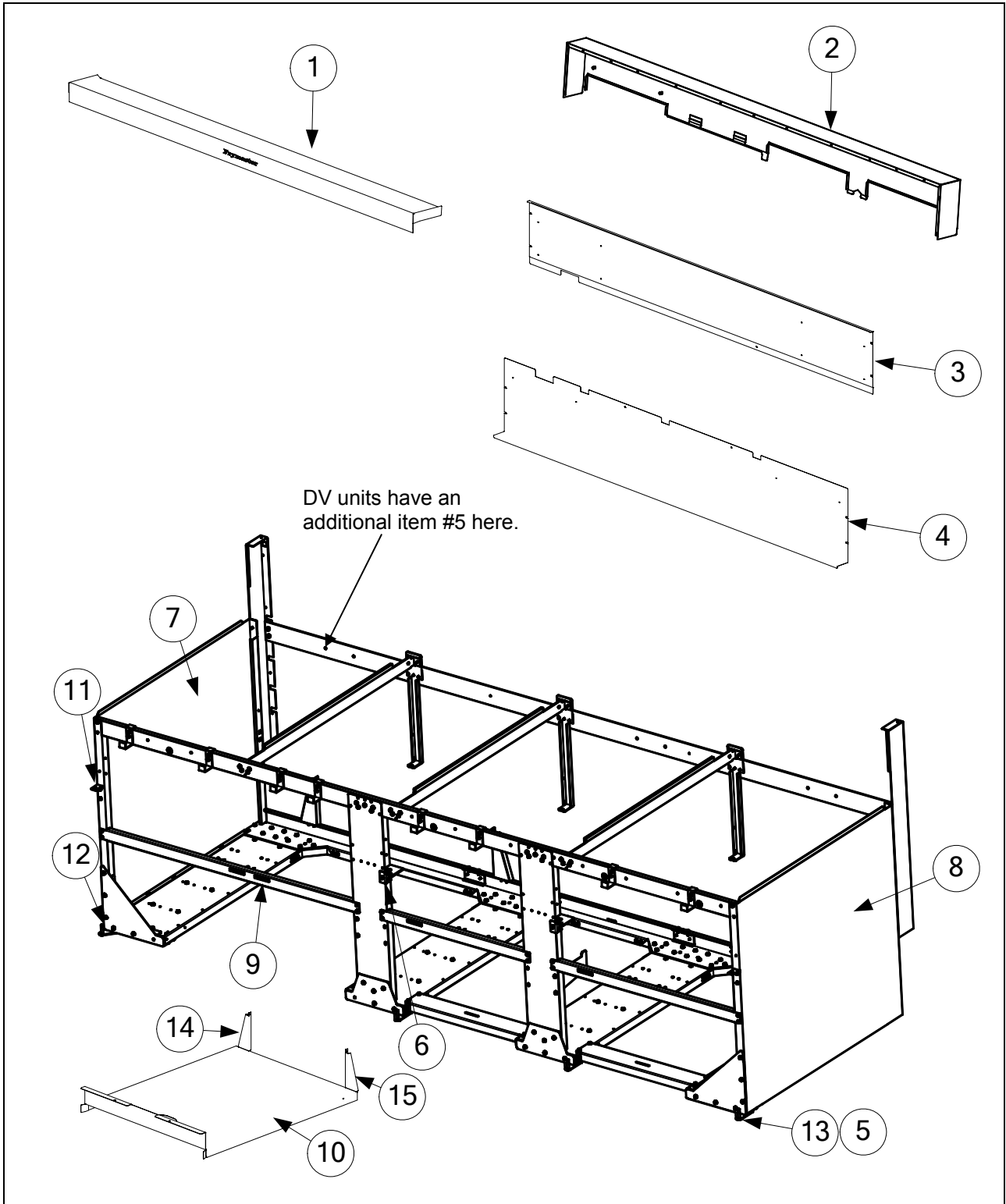

2.1.1.3 FP128/236 Cabinet and Related Components (cont.)

Item	Part Number	Description
	106-3792	Cabinet Assembly FP128/236 (<i>use 106-5891 for FP128DV/236S</i>)
1	106-3811	Topcap Assembly, FP128/236S (<i>use 106-5897 for FP128DV/236S</i>)
2	106-3815	Tilt Housing Assembly, FP128/236S
3	200-6528	Back, FP128/236S Upper Cabinet
4	200-6529	Back, FP128/236S Lower Cabinet
5	200-6376	Plate, Door Hinge Mounting
6	210-6343	Hinge, Upper, Door
	230-7192	Hinge, Lower
7	211-8234	Side, LH Cabinet
8	212-8234	Side, RH Cabinet
9	810-2346	Magnet, Door
10	823-7237	Lid, Filter Pan
11	810-1508	Hinge, Door Universal
12	230-4998	Hinge, W/A, LH Lower Door
13	823-4811	Hinge, W/A RH Lower Door
14	202-6593	Bracket, Filter Pan Cover Mounting
15	201-6593	Bracket, Filter Pan Cover Mounting

* Not Illustrated

2.3.2 Door Components

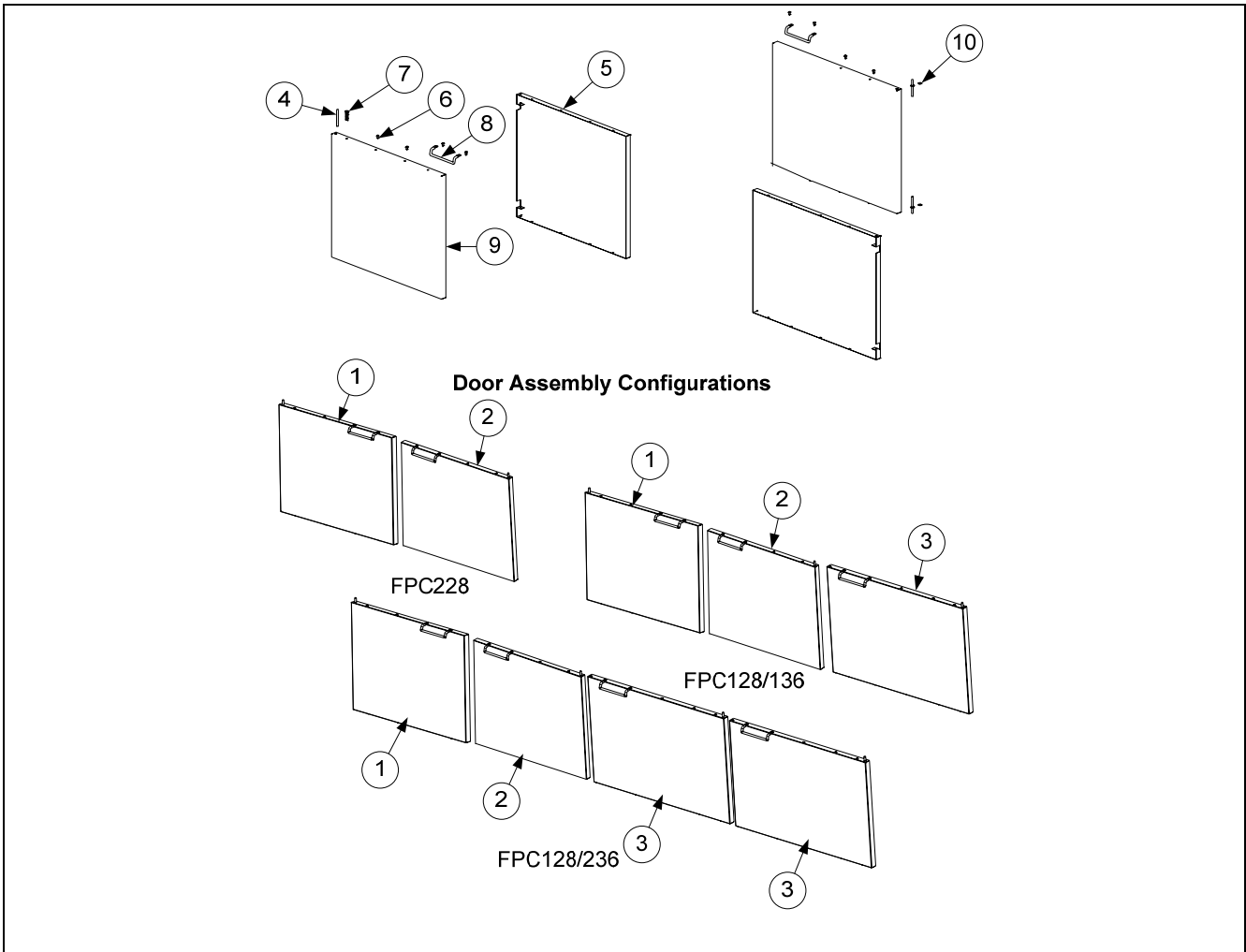

Item	Part Number	Description
1	106-3677	Door Assembly, FP28 Left Door
2	106-3676	Door Assembly, FP28 Right Door
3	106-3731	Door Assembly, FP36
4	106-4067SP	Pin Assembly, Door Slotted W/Keeper
7	826-1343	Spring, JCF Door Hinge Lock (Pkg. of 10)
8	810-1422	Handle, Wireform Door
*	210-8077	Handle, Euro Door
10	809-0413	Spacer, 1/4" X .160 8 Gauge Nylon

2.3.3 Dump Station Components

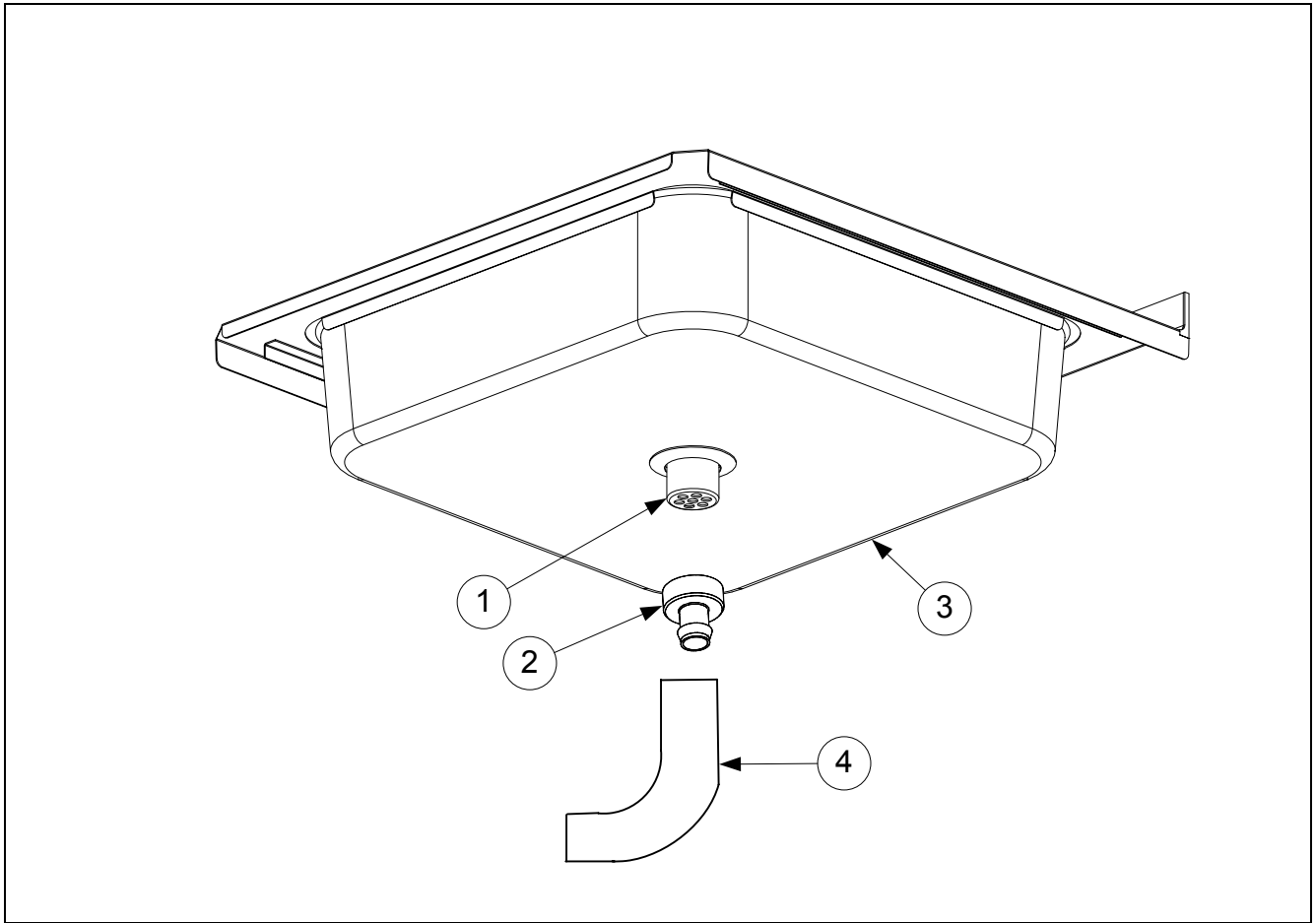

Item	Part Number	Description
*	106-3928SP	Pan Assembly, Dump Station
1	813-0396	Drain, Sink 1½" NPS (includes gasket PN 816-0129)
2	813-0883	Barb Fitting 1-inch Hose X 1½-inch NPSM
3	823-4620	Holder W/A, Dump Station Pan
4	812-1699	Hose, 1" ID x 1.405 OD x 16.50"
*	826-2183	Sink, Drain Kit
*	809-0374	Clamp, 1", Hose, Worm Gear

2.4 Computer and Related Components

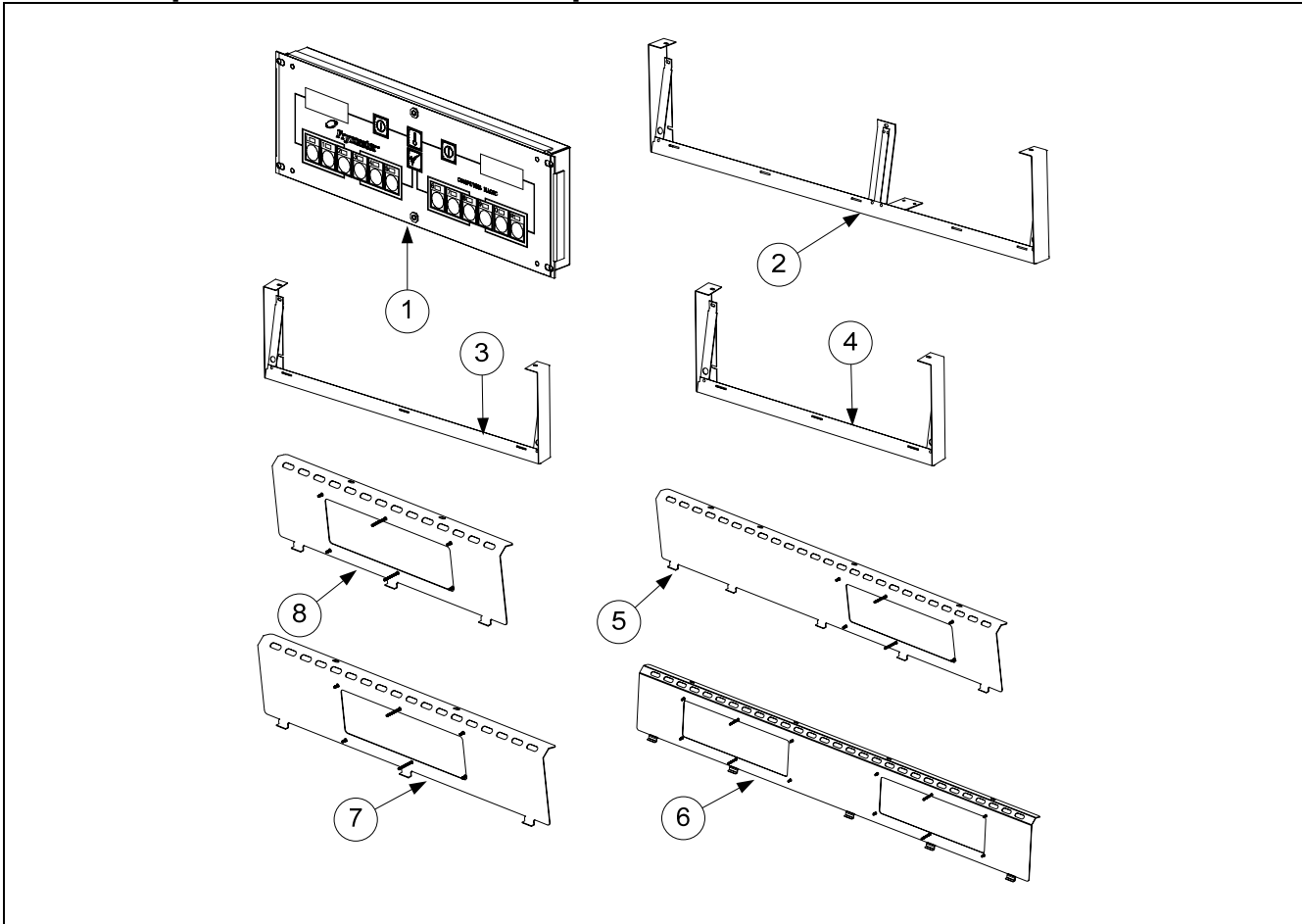

Item	Part Number	Description
1		Computers
	826-2389	Computer, FP228
	826-2388	FP28 Full Vat
	106-7177	FP28 Dual Vat
	826-2387	FP36 Full Vat
2	106-3647	Frame Assembly, FP128S Control Panel
*	106-3587	Frame Assembly, FP228S Control Panel
3	106-3648	Frame Assembly, FP136 Control Panel
4	106-3794	Frame Assembly, FP128/236S Control Panel
*	200-6037	Bracket, Center Control Panel
*	824-1251	Spacer, Computer Panel
5	823-4549	Bezel W/A, FP28 Control Panel Frame
6	823-4689	Bezel W/A, FP228 Control Panel Frame
7	823-4590	Bezel W/A, FP36S Control Panel Frame
8	823-4658	Bezel W/A, FP128/236S Control Panel Frame

* Not Illustrated

2.5 Contactor and Power Cord Box Assembly

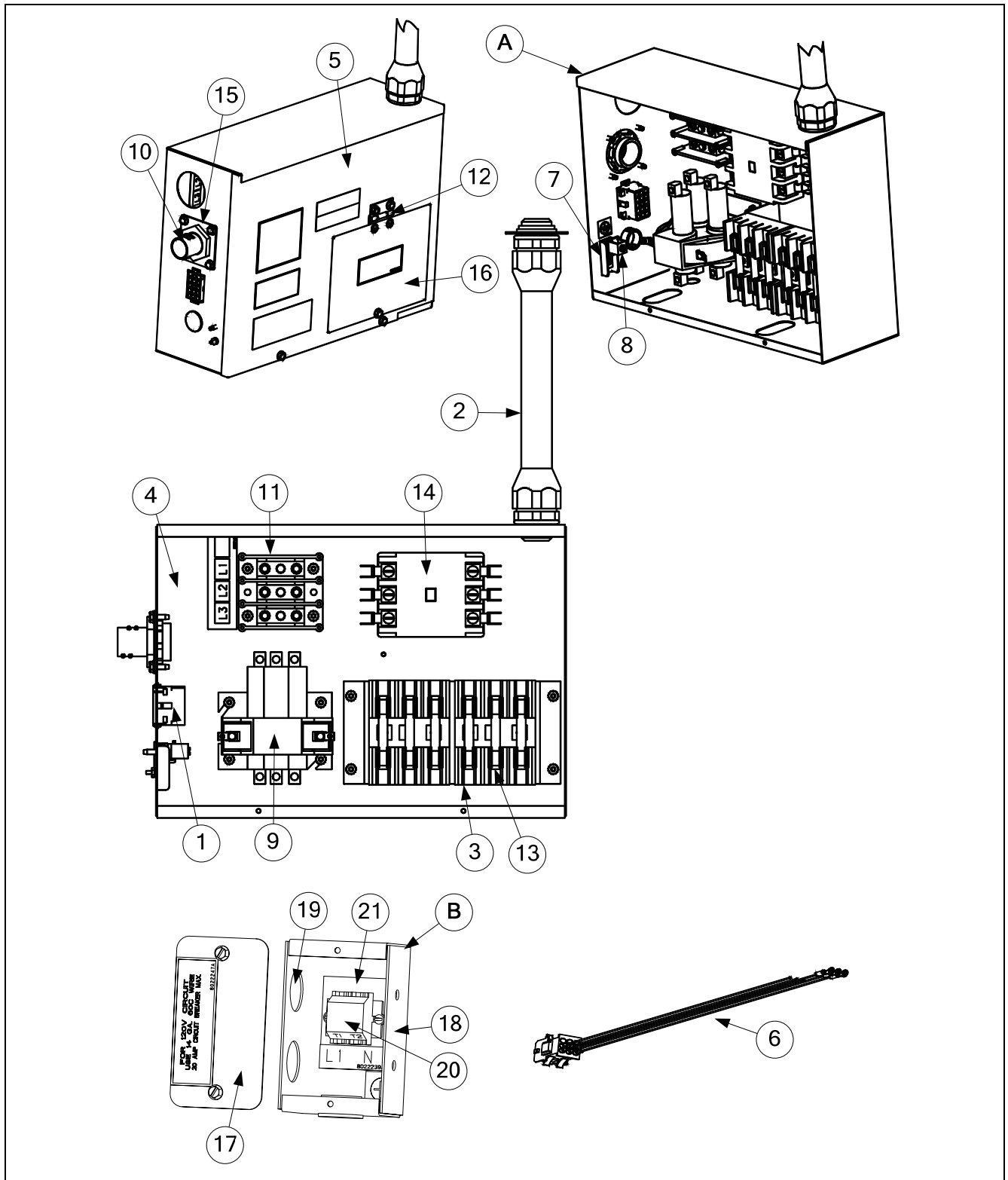

2.5 Contactor and Power Cord Box Assembly (cont.)

Item	Part Number	Description
A	106-4530	Box, Assembly, FP28/36S 208/240V LT Contactor
	106-4531	Box, Assembly, FP28/36S 208/240V RT Contactor (Shown in diagram)
	106-4527	Box Assembly, FP28/36S 480V LT Contactor FV (Use 106-5930 FP28DV/36)
	106-4528	Box Assembly, FP28/36S 480V RT Contactor
1	807-0159	Connector 12-pin Female
2	812-1685	Conduit, Flexible 3/4-inch x 8.0-inch
3	807-0501	Fuse Block, Buss #2968 3-Pole
4	106-4530	Box, FP28/36 LT FV Contactor 208/240V (Use 106-5813 LT FP28DV/36)
	106-4531	Box, FP28/36 RT Contactor 208/240V
5	221-3527	Cover, Contactor Box LT FV (Use 200-0798 LT FP28DV/36)
	222-3527	Cover, Contactor Box RT
6	106-4192	Harness, 208/240V Contactor Box Basket Lift
	106-4180	Harness, 480V Contactor Box Basket Lift
7	200-6809	Bracket, Ground Lug Holder
8	807-0070	Terminal, Ground Lug
9	807-0884	Contactor Mercury 240V 50A
10	810-2866	Connector, 1" Screw In Flex
11	807-3610	Block, Dean Terminal 1501-AL-9CU
12	810-0519	Hinge, Utility
16	807-2240	Fuse, 60 AMP 300VAC
17	807-2283	Contactor, 63Amp Mechanical 24V Coil (Used on 208/240V)
	810-1202	Contactor, 40 Amp 600V 3 Pole (Used on 480V)
23	200-8590	Plate, Component Box Cable Mtg
25	200-2334	Door, Contactor Box
B	106-3964	Box Assembly, 120V Power Cord (480V Units Only)
26	200-8030	Cover, Electrical Handy Box
27	824-1378	Box, FP28/36 120V Power Cord
28	807-1947	Plug, .875 Diameter Dome
31	810-1164	Block, 1 Plc Screwless Terminal
32	816-0217	Paper, CE Single Terminal Black Insulating
*	WIR0607	Wire Assembly, FP28/36S Contactor Box Fuse (Used on 208/240V)
*	WIR0598	Wire Assembly, FP28/36S Contactor Box (Used on 480V)
*	WIR0690	Wire Assembly FP28DV Contactor Box (Used on 480V)
*	WIR0688	Wire Assembly FP28DV Contactor Box (used on 480V)

* Not Illustrated

2.6 Terminal Block Mount Assembly

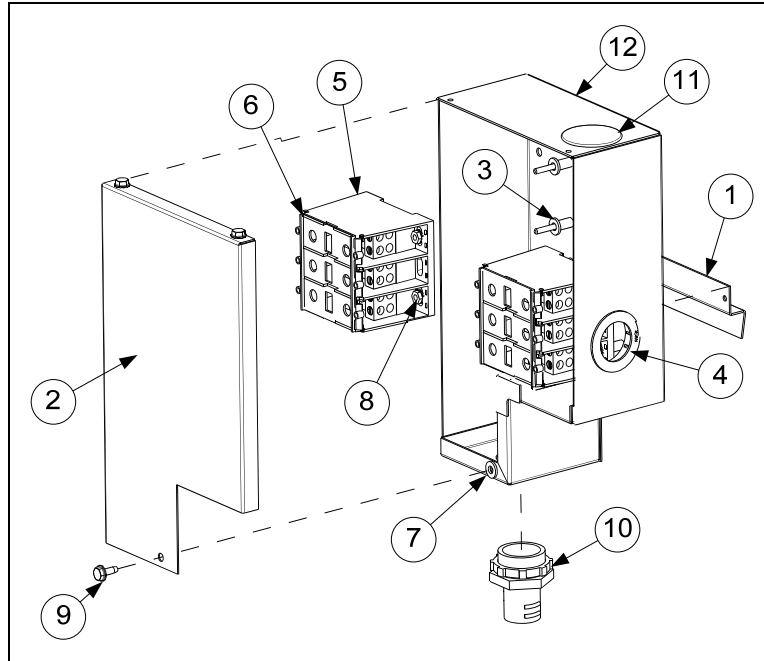

Item	Part Number	Description
	106-4471	Terminal Block Mount Assembly <i>(Use 106-6176 for RH mount Assembly)</i>
1	200-8525	Spacer, Terminal Block Mounting
2	200-9409	Cover, Terminal Block
3	200-9410	Spacer, .250 OD x .035 Wall x .50 Long
4	807-1043	Bushing, 1.06 ID
5	807-4080	Block, 600v 175A CU / 135A AL 3 Pole Power Terminal
6	807-4081	Cover, Plastic Power Terminal Block
10	810-2866	Connector, 1" Screw in Flex <i>(Use 807-4325 for 90° connector)</i>
11	810-2965	Plug, 1-1/4" : Snap In
12	823-4976	Mount W/A, Terminal Block

2.7 Component Box Assembly

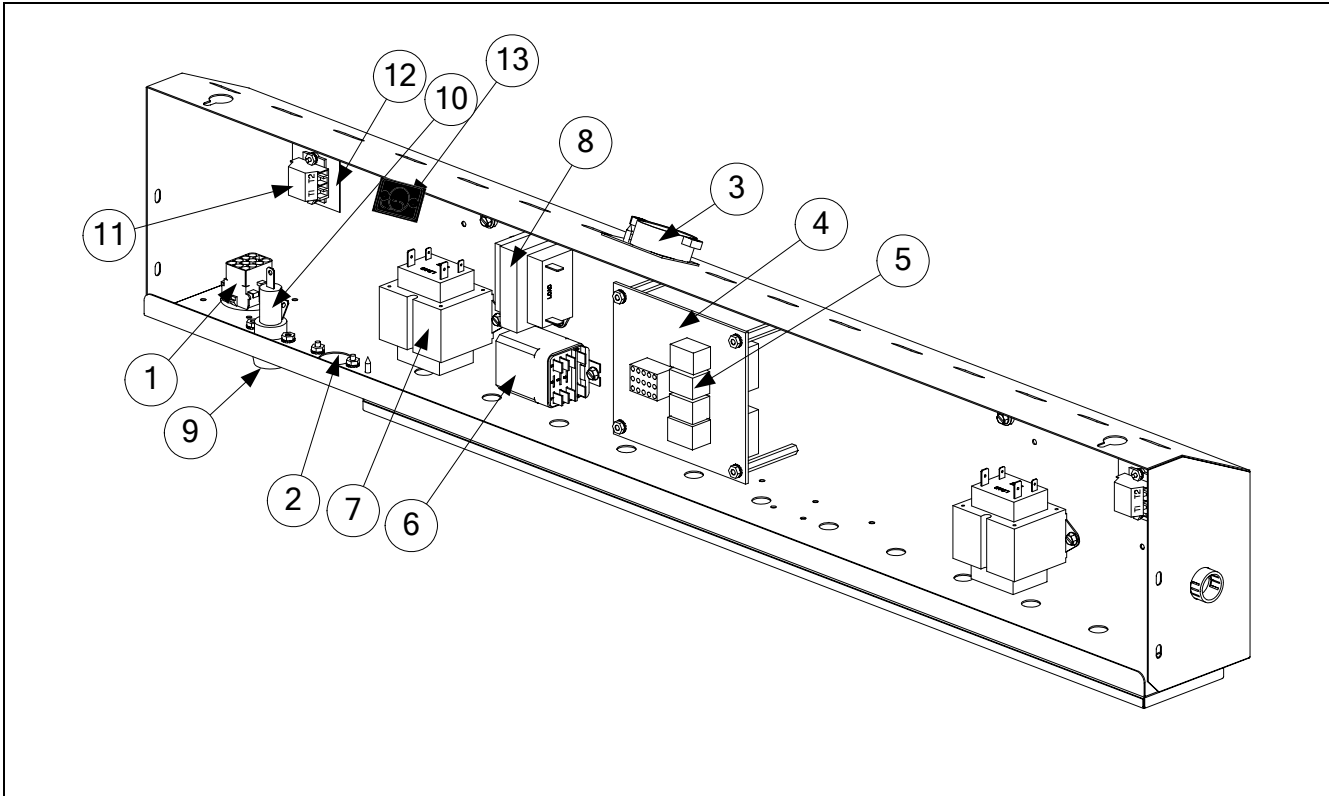

Item	Part Number	Description
1	809-0159	12-Pin connector FM
2	200-6506	Plate, Component Box Fuse Cover
3	806-3660	Sound Device, High Output
*	810-3141	Sound Device, SMT
4	806-6336	PCB Assembly, Interface (FV) Common Elect
*	106-6660	PCB Assembly, Interface (FV) SMT
5	807-3932	Relay, 12VDC SPDT 12A Sealed
6	807-0670	Relay, Midtex DPDT 24V
7	807-0680	Transformer 208/240/24V 50/60 20VA (208/240)
	807-0800	Transformer 120V 50/60-24V 50VA (480V)
8	807-0979	Transformer 208/240/24VAC 50/60 43VA (208/240)
	807-0855	Transformer 120V 50/60-12V 20VA (480V)
9	807-0922	Holder, Buss Fuse HPS
10	807-2278	Fuse, 20 Amp
11	810-1164	Block, 1 Plc Screwless Terminal
12	816-0217	Paper, Insulating Terminal Block CE
13	200-6506	Cover, Component Box Hole 480V
*	WIR0609	Wire Assembly 208/240V LT Component Box
*	WIR0610	Wire Assembly 208/240V RT Component Box
*	WIR0611	Wire Assembly 208/240V Filter Control
*	WIR0601	Wire Assembly 480V Filter Controls
*	WIR0599	Wire Assembly 480V LT Component Box
*	WIR0600	Wire Assembly 480V RT Component Box

* Not Illustrated

2.8 Filter Pan and Related Components - Built-in Filtration

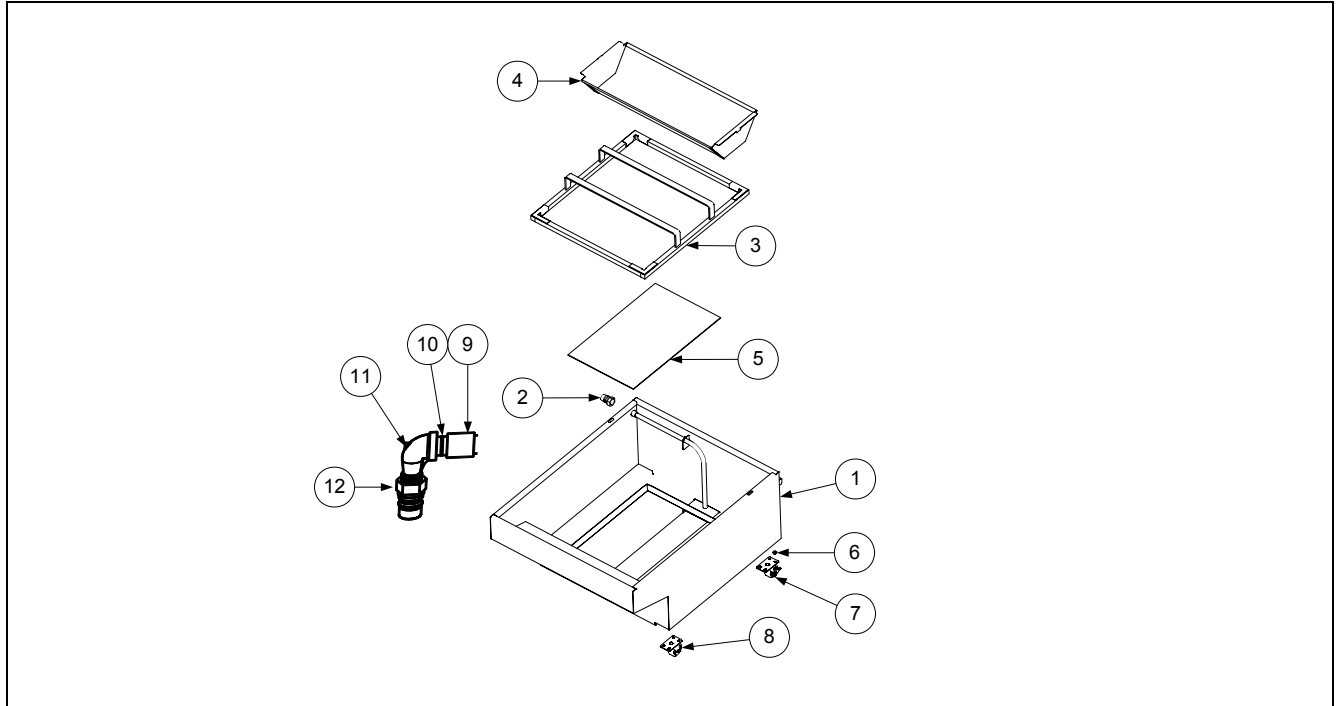

Item	Part Number	Description
	106-4290	Complete Filter Pan Assembly FPC228
	106-4291	Complete Filter Pan Assembly FPC128/136-236
1	106-4289	Pan Assembly, Filter
2	810-0487	Quick Disconnect, 1/2" Male Used on FP28/36 Only
3	823-4829	Ring, Hold Down
4	823-5530	Tray, Filter Pan Crumb
5	200-7196	Screen, FP3 Sana Grid
6	809-0059	Nut, Grip 1/4" - 20 HX NP
7	810-2806	Caster, Swivel W/Brake
8	810-2805	Caster, Swivel
9	813-0037	Coupling, 1/2" NPT x 1-1/8" FP228 only
10	813-0022	Nipple, 1/2" x Close NPT BM FP228 only
11	813-0165	Elbow, ST 1/2" x 1/2" NPT 90° BM FP228 only
12	810-0487	Coupling, Male FP228only
*	802-2264	Label, Filter Pan Notice
*	802-2257	Label, Filter Pan Assembly
*	802-1604	Label, Hot Surface

* Not Illustrated

2.9 Frypot and Related Components

2.9.1.1 Frypot and Drain Valve Components DONE

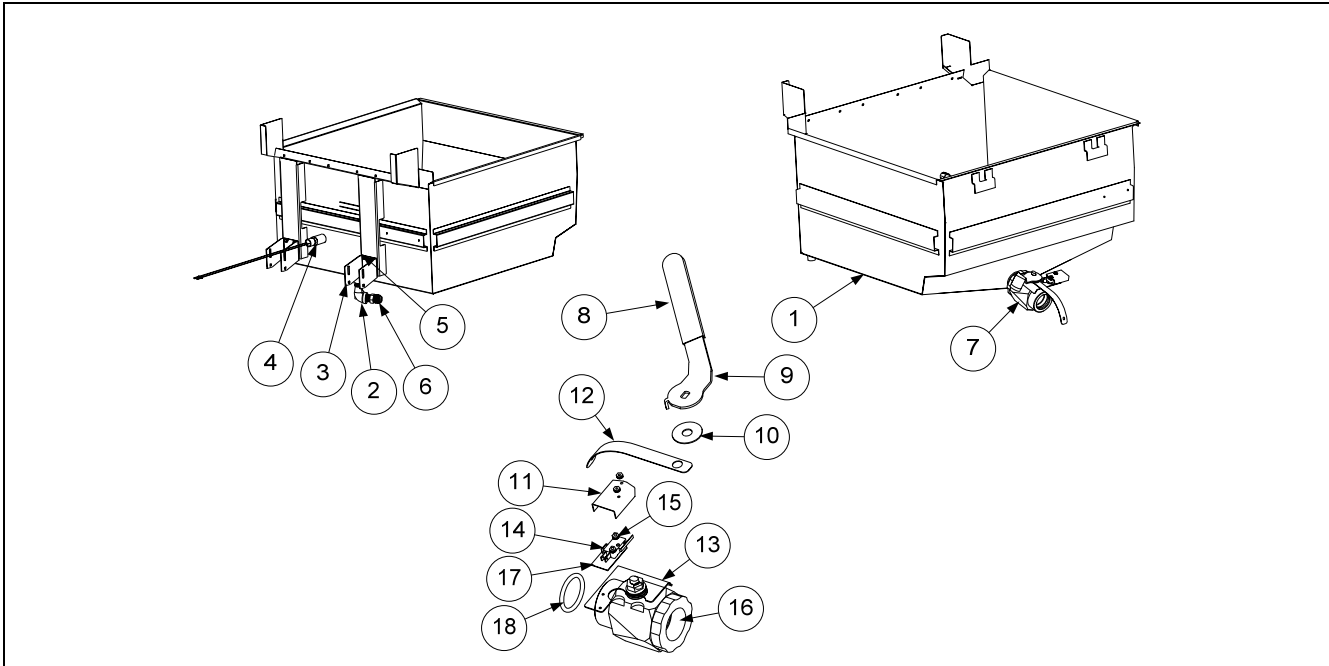

Item	Part Number	Description
*	106-5916	Frypot Assembly, FP14 (FP28DV) 55lbs (<i>no float switch</i>)
	106-4198	Frypot Assembly, FP28 110 lbs (<i>no float switch</i>)
	106-4203	Frypot Assembly, FP36S 160 lbs (<i>no float switch</i>)
1	823-4815	Frypot W/A, Wal-mart FP28FV110# (<i>no float switch</i>)
	823-4816	Frypot W/A, Wal-mart FP36FV 160# (<i>no float switch</i>)
*	823-5597	Frypot W/A, Wal-mart FP14 (FP28DV) 55# (<i>no float switch</i>)
2	813-0165	EL, ST 1/2" NPT 90deg BM
3	210-6765	Bracket, FP28/36 Lower Spring
4	806-8035	Thermostat Assembly, 435° Hi-Limit
5	826-1374	Screw, #10- 1/2" Hex Washer HD NP (Pkg. of 25)
*	810-0297	Spring Element Lift Blue 110# FP28
*	810-1546	Spring Element Lift Green 160# FP36
6	810-1668	Adapter, Male 5/8" O.D. X 1/2"
7	106-3756	Valve Assembly, FP28/36 Frypot Drain (<i>Use 106-5917 for FP14 (FP28DV)</i>)
8	816-0405	Sleeve, Drain Handle Red Plastic
9	210-7077	Handle, Drain Valve (<i>Use 230-0892 for FP14 (FP28DV)</i>)
10	200-1617	Washer, Drain Microswitch K118G
11	200-5694	Cover, Switch Drain FPP
12	200-6345	Bracket, Drain Valve Mounting
13	106-3745	Bracket Assembly
14	807-2103	Switch, CE Micro Straight Lever
15	826-1366	Nut, 4-40 KEPS HEX w/external Tooth (Pkg. of 25)
16	810-2783	Valve, 1/2" Full Port Drain
17	816-0220	Insulation, RF Switch
18	816-0544	O-Ring, Seal

* Not Illustrated

2.9.1.2 Drain Components DONE

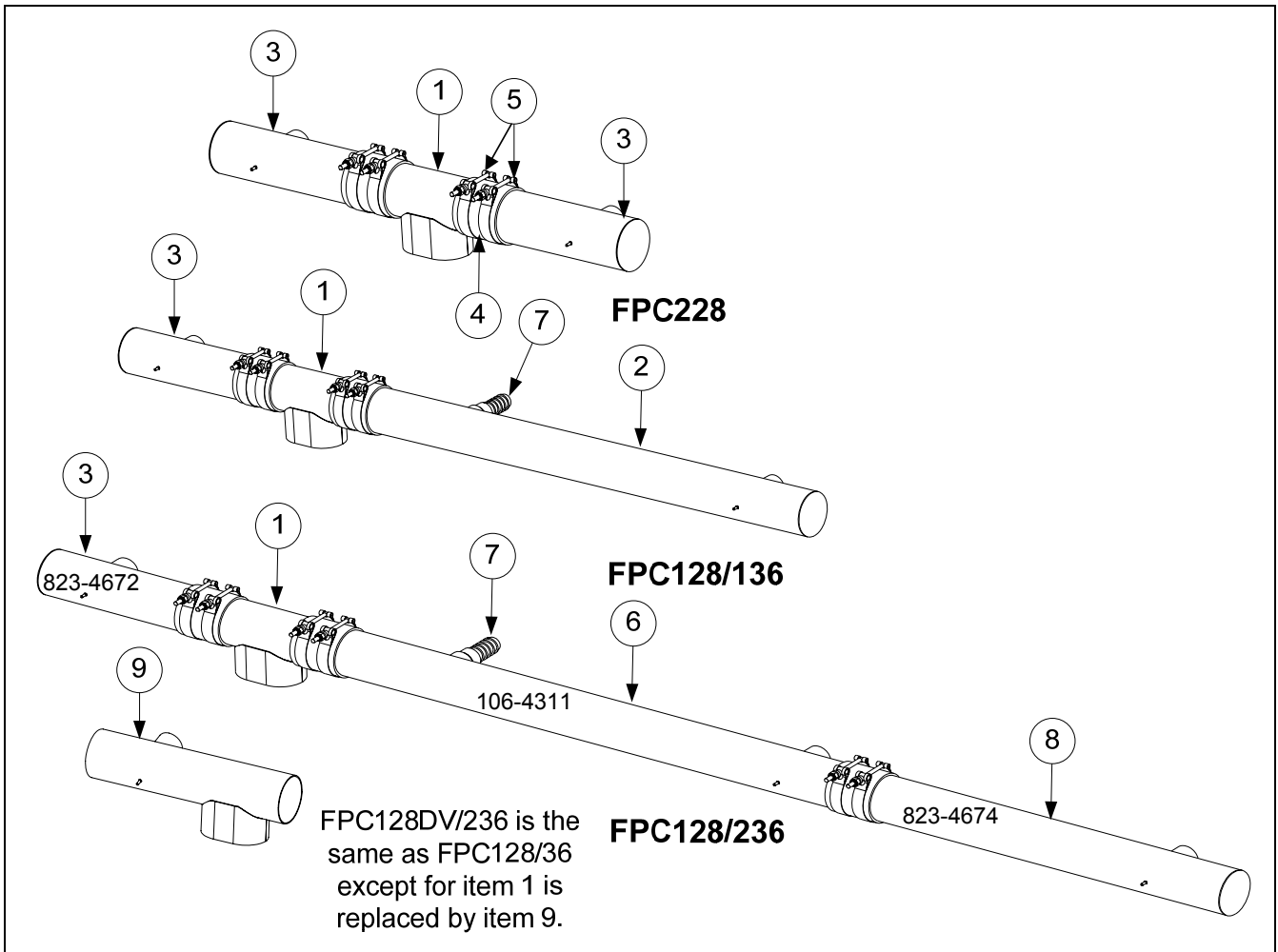

Item	Part Number	Description
1	823-4846	3" Drain Dump
2	106-4310	3" Drain Tube Assembly, Right Side FPC128/136 (Includes item #7)
3	823-4672	3" Drain Tube, Left Side
4	816-0729	5" Connecting Sleeve
5	809-0969	3" Clamp
*	KIT6214	Round Drain Boot Kit (includes 2 clamps and 1 boot)
6	106-4311	3" Drain Tube Assembly Center FPC128/236 (includes item #7)
7	813-0525	Barb Fitting 1" Pipe to 1" Hose
8	823-4674	3" Drain Tube Right Side FPC128/236
9	823-5663	3" Drain Tube Dump, FP28DV

* Not Illustrated.

2.10 Elements and Related Components

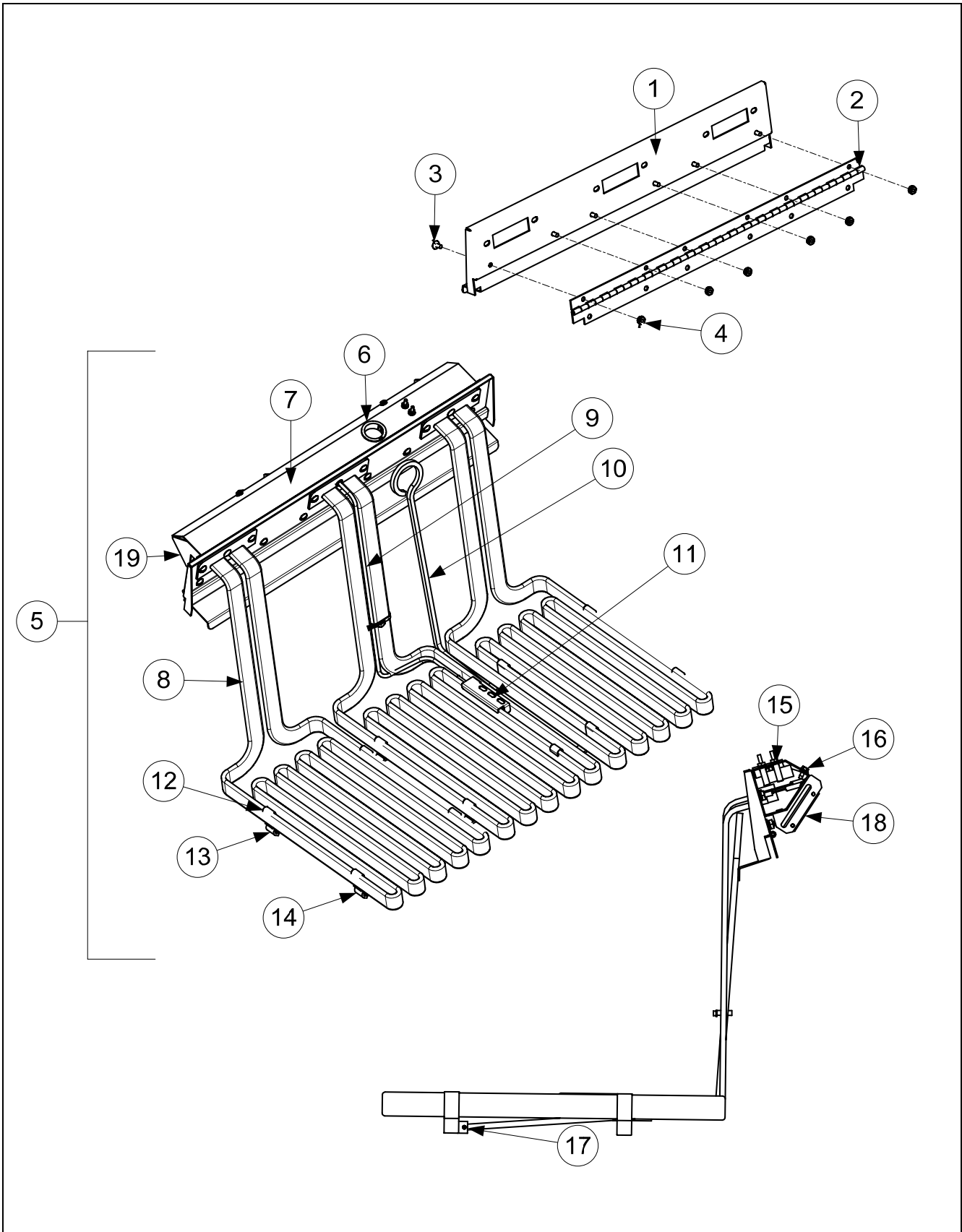

2.10 Elements and Related Components (cont.)

Item	Part Number	Description
	106-4200	Tilt Plate Assembly FP28 <i>(Use 106-5919 for FP28DV)</i>
	106-4209	Tilt Plate Assembly FP36 (shown in diagram)
1	210-7154	Tilt Plate FP28 <i>(Use 230-0704 for FP28DV)</i>
	210-7161	Tilt Plate FP36
2	810-2751	Hinge, Stainless Steel <i>(Use 810-3020 for FP28DV)</i>
5	108-1931	Element Assy,FP36 480v 36kw
	108-1933	Element,FP36 208/220v 26.7/30k
	108-1934	Element Assy,FP28 480v 28.6kw
	108-1935	Element Assy,FP28 240v 28.6kw
	108-1936	Element Assy,FP28 208/220v 25.6kw
	108-1937	Element Assy,FP14 480v 14.3kw
6	810-3012	Heyco Plastic Bushing, 1"
7	220-1250	Element Tilt Drip Pan FP28/38 <i>(Use 220-1252 for FP28DV)</i>
8	807-4060	Element, FP28 208/220V
	807-4062	Element, FP36 208/220V
	807-4059	Element, FP28 240V
	807-4061	Element, FP36 240V
	807-4038	Element, FP28 480V
	807-4051	Element, FP36 480V
9	826-2106	Probe Kit, FP28 Temperature
	826-2107	Probe Kit, FP36 Temperature
10	810-2916	Handle, Element Lift
*	826-1364	Handle, Pin (25)
11	230-5041	Bracket, Element Probe
12	910-2042	Clamp, Element <i>(Use 230-0917 for FP28DV)</i>
13	210-8261	Bracket, FP28 Element Support, Rear <i>(Use 230-0714 for FP28DV)</i>
	210-8262	Bracket, FP36 Element Support, Rear
14	823-7318	Bracket, FP28 Element Support, Front <i>(Use 823-7319 for FP28DV)</i>
	823-7309	Bracket, FP36 Element Support, Front
15	807-1570	Clip, Switch
16	826-2741	Tilt Switch Assembly, Mercury
*	108-1893	Tilt Switch, Mechanical
17	810-1212	Slotted Pin
18	816-0214	Bar, Spring Slot Bracket
*	816-0480	Plug .375 OD Dome

NOTE: This manual makes no references to previous models with rounded elements and float switches. For parts associated with that fryer refer to 2836 Service and Parts Manual part number 819-6049.

* Not Illustrated

2.11 Oil Disposal Wand

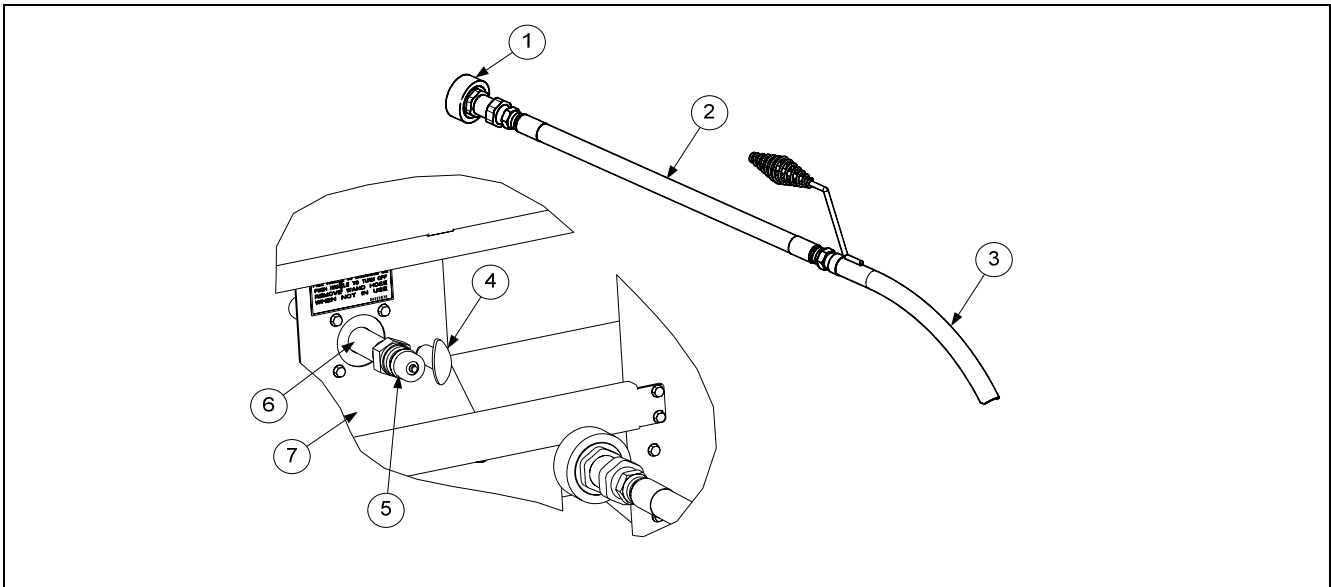

Item	Part Number	Description
	806-7459SP	Oil Discard Wand Assembly
1	810-0490	Quick Disconnect, 1/2-inch female
2	810-1471	Hose
3	810-1091	Wand
*	826-2052	Oil Return Plumbing Kit FP228
*	826-2053	Oil Return Plumbing Kit FP128/136
*	826-2054	Oil Return Plumbing Kit FP128/236
4	810-0680	T-Handle
*	809-0417	Flange Nut - to mount rod and handle
5	810-0487	Disconnect, Coupling 1/2" Male
6	823-4924	Nipple with Bracket, 1/2" NPT x 7.0"
7	200-8284	Wand Bracket – FPC128/136 and FPC128/236
*	200-8402	Wand Bracket – FPC 228

* Not Illustrated

2.12 Oil Return Assembly

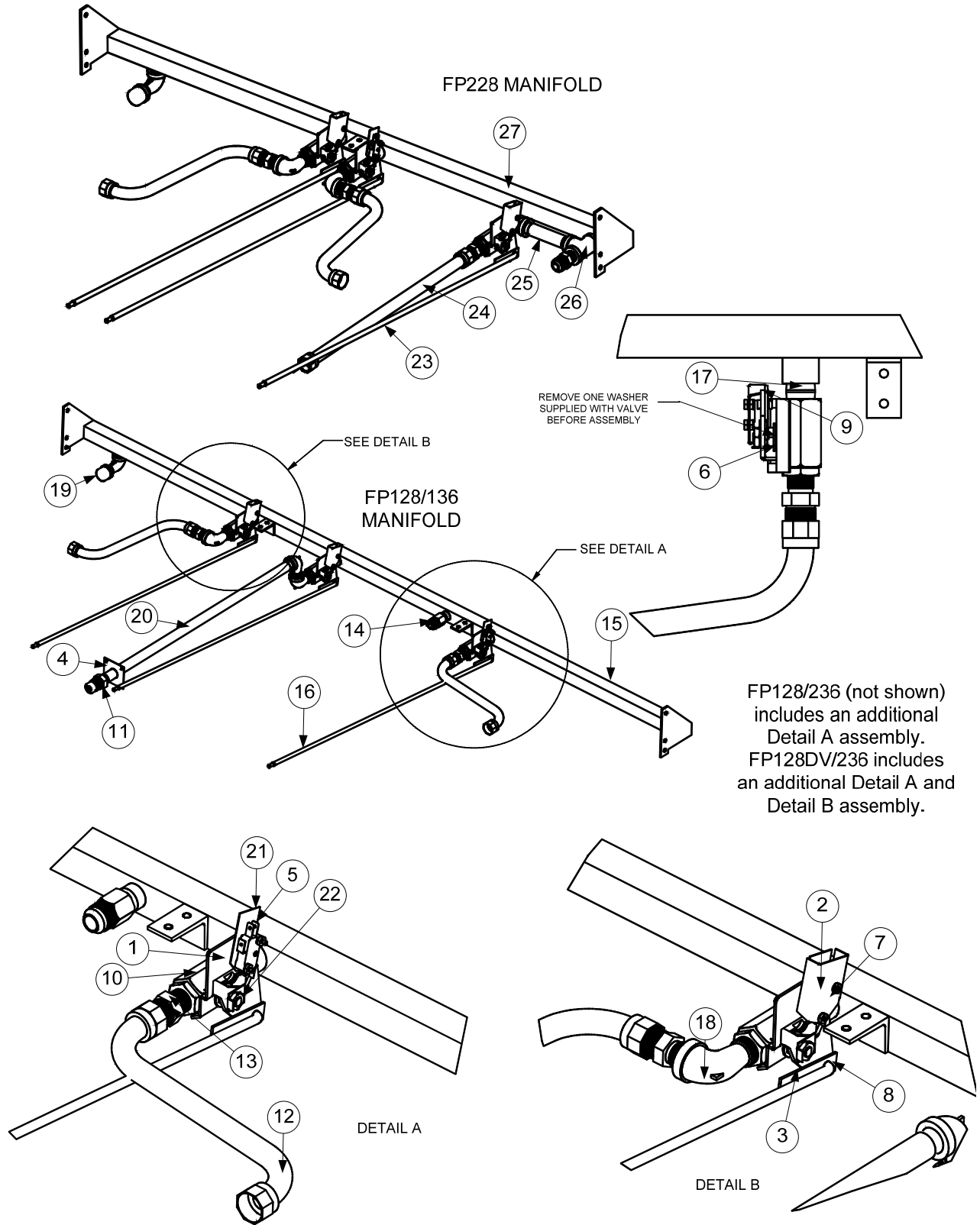

2.12 Return Assembly (cont.)

Item	Part Number	Description
	106-3758	FP228 Oil Return Assembly
	106-3759	FPC128/136 Oil Return Assembly
	106-3808	FPC128/236 Oil Return Assembly
	106-5944	FPC128DV/236 Oil Return Assembly
1	106-3925	Bracket, FP28/36 ½" Valve Microswitch
2	200-6799	Cover, Safety Switch
3	200-8133	Handle, ½" Valve
4	200-8285	Plate, FP28/36 Oil Discard Support
5	807-2103	Switch, CE Micro Straight Lever
8	809-0601	Clip, Clevis
9	809-0885	Washer, ⅜" X 1" X .083"
10	810-0278	Valve, ½" Ball
11	810-0487	Coupling, Male
12	810-1057	Flexline 5/8" O.D. x 13.00"
13	810-1668	Adaptor, Male 5/8" O.D. x ½"
14	810-1669	Adaptor, Female 7/8" O.D. x ½"
15	810-2756	Manifold, FP128/136S Oil Return
	810-2779	Manifold, FP128/236S-FP128DV/236S Oil Return
16	826-2780	FP28/36 Oil Return Rod Service Kit (right-facing rod, clevis clip, vinyl cap)
*	220-6114	Left-facing Oil Return Rod for FP228
*	220-6115	Right-facing Oil Return Rod for FP228 and FP 128/236
17	813-0022	Nipple, ½" x Close N.P.T. B.M.
18	813-0165	Elbow, ST ½" x ½" NPT 90° BM
19	813-0463	Plug, ½" Countersink
20	813-0541	Nipple, ½" NPT x 25.50 BM
21	816-0220	Insulation, RF Switch
22	900-2935	Retainer, Nut Oil Return Valve
23	810-2845	Rod Assembly, FP28/36 VAND
24	810-1369	Flexline 5/8" x 11.50"
25	813-0093	Nipple, ½" x 4" NPT BM
26	813-0003	Tee, ½" x ½" x ½" BM
27	810-2754	Manifold, FP228 Oil Return

2.13 Filter Pump Assembly

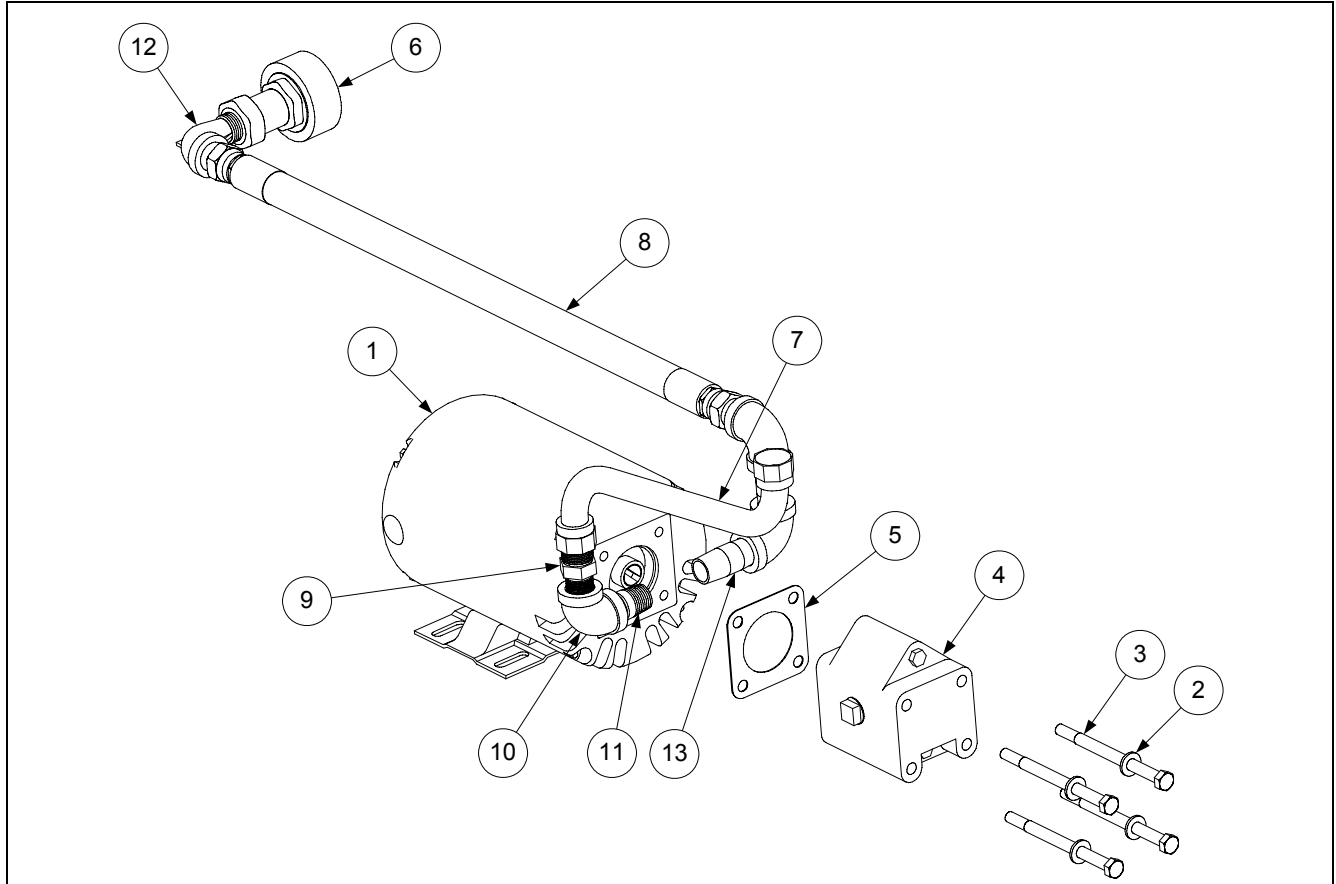

Item	Part Number	Description
1	826-1756	Motor, Kit 208V 50/60Hz
	826-1270	Motor, Kit 230V 50/60Hz
	826-1712	Motor, Kit 115 V 60 Hz
2	809-0194	Washer, Flat 5/16"
3	809-0514	Cap Screw, 5/16" – 18 HX HD
4	826-1264	Pump and Gasket Kit, Viking 4 GPM 2-Piece
5	816-0093	Gasket, Pump/Motor
6	810-0490	Quick Disconnect 1/2" Female
7	810-1057	Flexline, 5/8" X 13" Long
8	810-1471	Hose, Oil Discharge 24"
9	810-1668	Adapter, Male 5/8"O.D. X 1/2 "
10	813-0062	Elbow, 1/2" 90° BM
11	813-0087	Nipple, 1/2" NPT X 1 1/2" BM
12	813-0165	Elbow, ST 1/2" NPT 90° BM
13	813-0298	Nipple, 1/2" NPT X 2.0" BM

2.14 Wiring Harnesses and Cables

Item	Part Number	Description
		Basket Lift Harnesses
	106-3776	Harness Assembly FP28/36S Modular Basket Lift with Relay
	106-4180	Harness, FP28/36 480V Controller Box to Basket Lift
	106-4181	Harness, FP28/36 480V Basket Lift Conduit
	106-4193	Harness, FPC28/36 208/240V Basket Lift Conduit
	106-4192	Harness, FP28/36 208/240V Controller Box to Basket Lift
	106-4944	Harness, FPC 28/36 208/240V B.L.
	106-4943	Harness, FPC 28/36 480V B.L.
		Component Box Harnesses
	106-3798	Harness, FP28/36 480V Component Box
	106-3800	Harness, FP28/36S Component Box Adj Jumper
	106-3801	Cable Assembly, FP28/36 120V Controls
	106-3984	Harness Assembly, FP28/36S 208/240V Component Box
	106-5952	Harness Assembly, FP28 DV Component Box
		Contactors Box Harnesses
	106-3786	Harness, FP28/36 480V Contactor Box Two-Wire with 15-pin FM
	106-3787	Harness, FP28/36 208/240V Contactor Box Two-Wire with 15-pin FM
	106-3789	Harness, FP28/36 208/240V Contactor Box Five-Wire with 12-pin Male
	106-5945	Harness, FP14 (FP28DV) 480V Contactor Box Two-Wire with 9-pin Male Plug
	106-3788	Harness FPP 28/36 480V Contactor Box
		Contactors to Component Box Harnesses
	106-3790	Cable, FP28/36S 208/240V Contactor Box to Component Box
	106-3791	Cable, FP28/36S 480V Contactor Box to Component Box
	106-5949	Cable Assembly, FP14 (FP28DV) 480V Contactor Box to Component Box
		Filter Pump Harnesses
	106-3805	Harness Assembly, FP28/36S Oil Return Switch
	106-3806	Cable Assembly, FP28/36S 480V Filter Pump
	106-4182	Harness, FP28/36 Oil Return Jumper
		Interface Board to Controller Wiring Harness
	806-2071	Interface Board to Controller Harness
		Tilt Switch/High-Limit/Probe Harnesses
	106-3802	Harness Assembly, FP28/36S Tilt/High-Limit/Probe
	106-3803	Harness Assembly, FP28/36S 480V Tilt/High-Limit/Probe
	106-3985	Harness, FP28/36S 208/240V Tilt/High-Limit/Probe
	106-4539	Harness, FP28/36S Tilt/High-Limit/Probe
	106-5942	Harness, FP14 (FP28DV) 480V Tilt/High-Limit/Probe

2.15 Fasteners

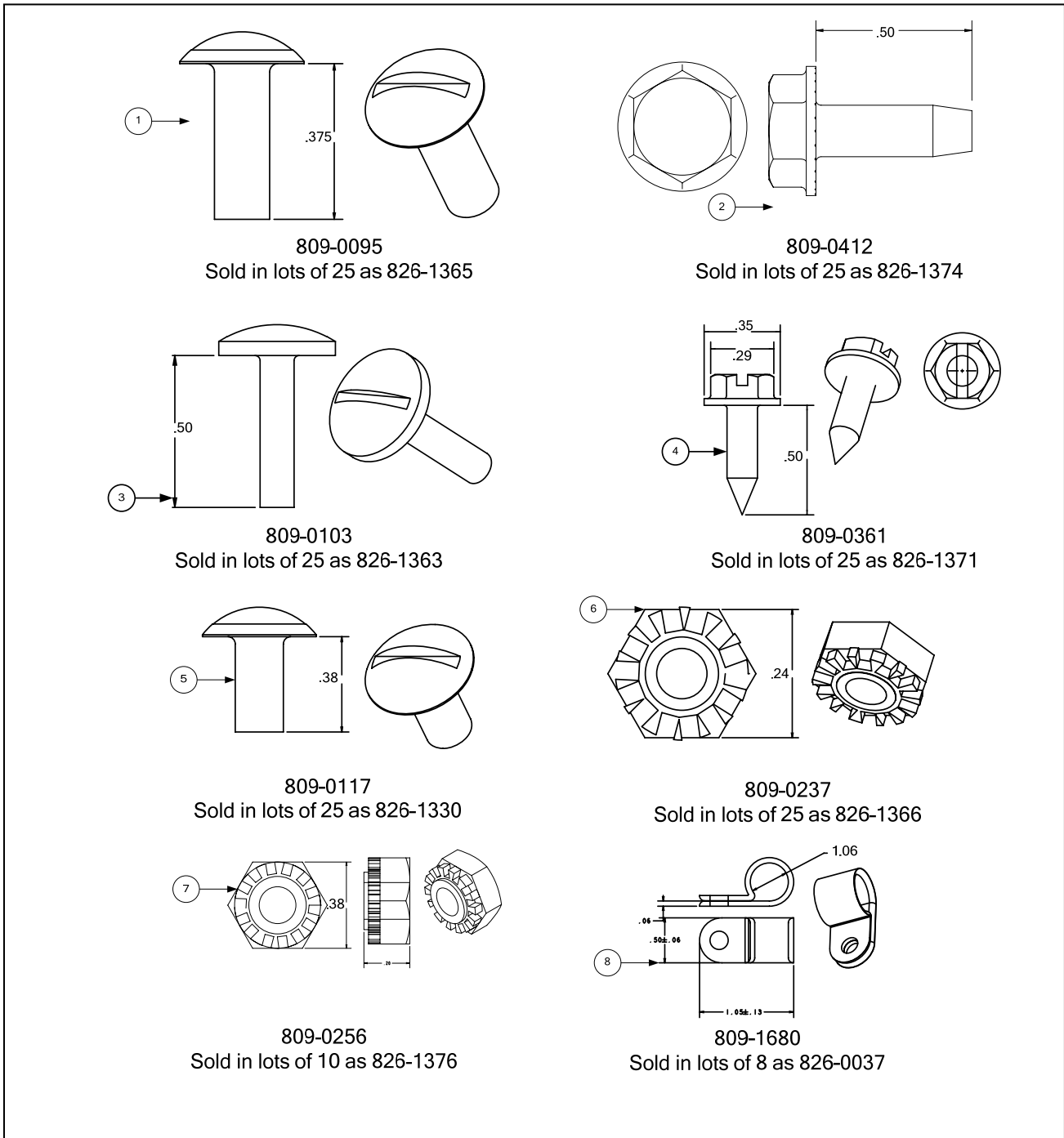

Item	Part Number	Description
1	826-1365	Screw, 6-32x3/8" (25)
2	826-1374	Screw #10-1/2 Hex (25)
3	826-1363	Screw, 8-32x1/2" (25)
4	826-1371	Screw, Drill #8x1/2" Hex (25)
5	826-1330	Screw, 10-32x3/8" (25)
6	826-1366	Nut, 4-40 KEPS Hex w/external tooth (25)

7	826-1376	Nut, KEPS, 10-32 (10)
8	826-1680	Clamp, Heyco #3327 (8)
*	826-1364	Handle, Pin (25)

2.16 Connectors

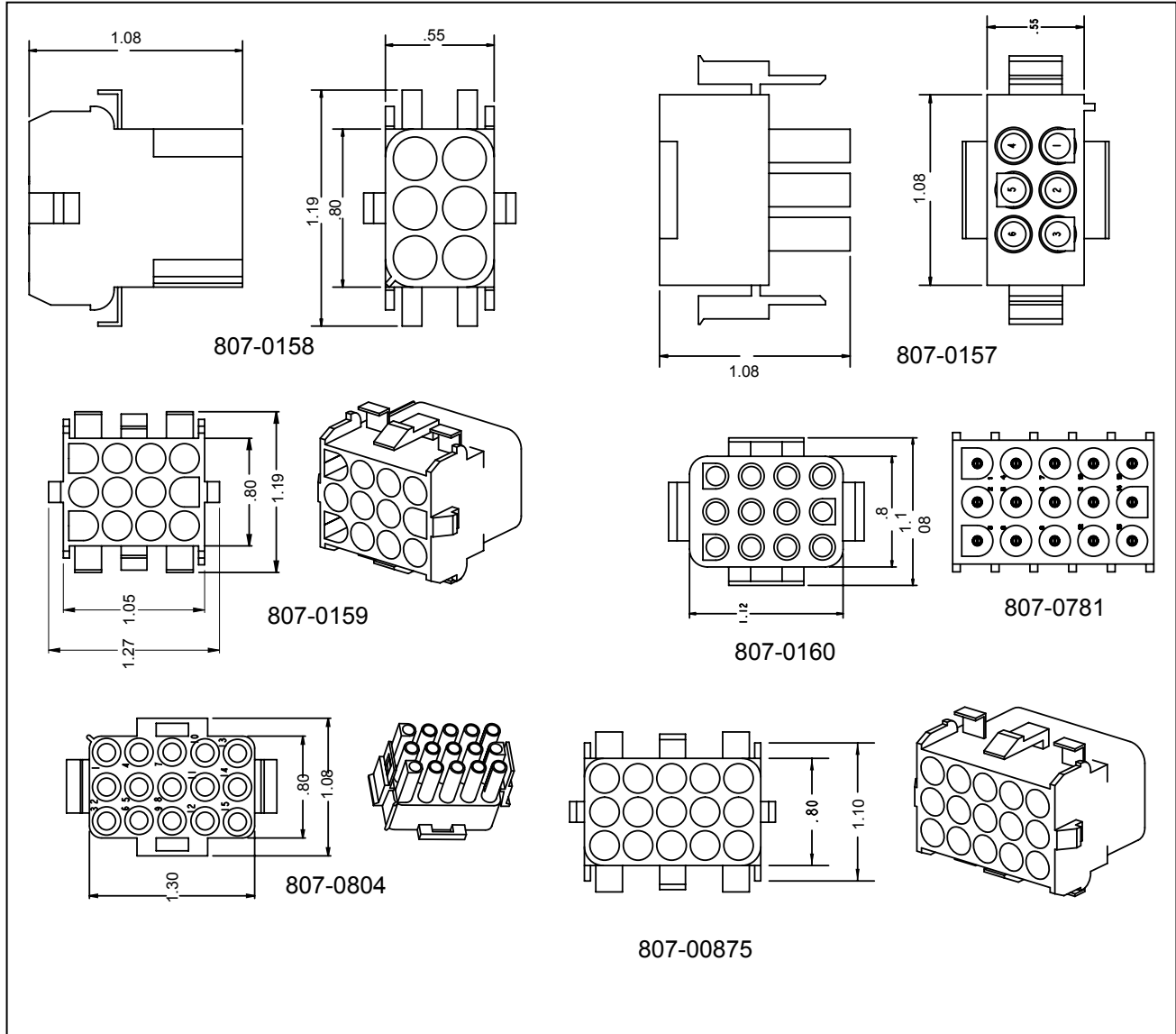

1	8070158	Connector 6 pin
2	8070157	Connector 6-pin
3	8070159	Connector 12 pin
4	8070160	Connector 12p
5	8070781	Connector 15 pin female
*	8070445	Connector 12 pin
6	8070804	Connector, 15 pin, male
7	8070875	Connector 15 pin, female



Shipping Address: 8700 Line Avenue, Shreveport, Louisiana 71106

TEL 1-318-865-1711

FAX (Parts) 1-318-219-7140

FAX (Tech Support) 1-318-219-7135

PRINTED IN THE UNITED STATES

SERVICE HOTLINE
1-800-551-8633

* 8196114 *

SEPT 11